



**SPLIT TYPE AIR-CONDITIONER**

---

# **Service Manual**

**ECO series**

**Models**

**KEX-09/12/18/24 KTGI**

**KEX-09/12/18/24 KTGO**

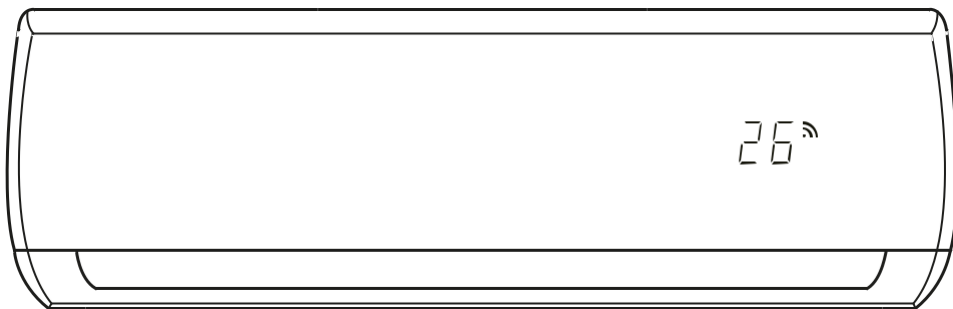



---

## **Table of Contents**

---

### **Safety Precautions**

Precautions

Information servicing(For flammable materials)

### **Specifications**

Model Reference

Pipe length and the Drop Height

Electrical Wiring Diagrams

### **Product Features**

Display Function

Safety Features

Basic Features

Optional Features

### **Maintenance**

First Time Installation Check

Refrigerant Recharge

Re-Installation

### **Indoor Unit Disassembly**

Dimension

Indoor Unit Disassembly

### **Outdoor Unit Disassembly**

Outdoor Unit Table

Dimension

Outdoor Unit Disassembly

---

---

## Table of Contents

---

### Troubleshooting

Safety Caution

General Troubleshooting

Complain Record Form

Information Inquiry

Error Diagnosis and Troubleshooting Without Error Code

Quick Maintenance by Error Code

Troubleshooting by Error Code

Check Procedures

### Appendix

Temperature Sensor Resistance Value Table for T1,T2,T3 and T4 (°C – K)

Temperature Sensor Resistance Value Table for TP(for some units) (°C – K)

Pressure On Service



Caution: Risk of fire  
(Required for R32/R290  
units only)





---

# Safety Precautions

## Contents

1.	Precautions .....	2
2.	Information servicing (For flammable materials).....	3

## 1. Precautions

To prevent personal injury, or property or unit damage, adhere to all precautionary measures and instructions outlined in this manual. Before servicing a unit, refer to this service manual and its relevant sections.

Failure to adhere to all precautionary measures listed in this section may result in personal injury, damage to the unit or to property, or in extreme cases, death.

 **WARNING** indicates a potentially hazardous situation which if not avoided could result in serious personal injury, or death.

 **CAUTION** indicates a potentially hazardous situation which if not avoided could result in minor or moderate personal injury, or unit damage.

### 1.1 In case of Accidents or Emergency

 **WARNING**

- ❑ If a gas leak is suspected, immediately turn off the gas and ventilate the area if a gas leak is suspected before turning the unit on.
- ❑ If strange sounds or smoke is detected from the unit, turn the breaker off and disconnect the power supply cable.
- ❑ If the unit comes into contact with liquid, contact an authorized service center.
- ❑ If liquid from the batteries makes contact with skin or clothing, immediately rinse or wash the area well with clean water.
- ❑ Do not insert hands or other objects into the air inlet or outlet while the unit is plugged in.
- ❑ Do not operate the unit with wet hands.
- ❑ Do not use a remote controller that has previously been exposed to battery damage or battery leakage.

 **CAUTION**

- ❑ Clean and ventilate the unit at regular intervals when operating it near a stove or near similar devices.
- ❑ Do not use the unit during severe weather conditions. If possible, remove the product from the window before such occurrences.

### 1.2 Pre-Installation and Installation

 **WARNING**

- ❑ Use this unit only on a dedicated circuit.
- ❑ Damage to the installation area could cause the unit to fall, potentially resulting in personal injury, property damage, or product failure.
- ❑ Only qualified personnel should disassemble, install, remove, or repair the unit.
- ❑ Only a qualified electrician should perform electrical work. For more information, contact your dealer, seller, or an authorized service center.

 **CAUTION**

- ❑ While unpacking be careful of sharp edges around the unit as well as the edges of the fins on the con-denser and evaporator.

### 1.3 Operation and Maintenance

 **WARNING**

- ❑ Do not use defective or under-rated circuit breakers.
  - ❑ Ensure the unit is properly grounded and that a dedicated circuit and breaker are installed.
- ❑ Do not modify or extend the power cable. Ensure the power cable is secure and not damaged during operation.
- ❑ Do not unplug the power supply plug during operation.
- ❑ Do not store or use flammable materials near the unit.
- ❑ Do not open the inlet grill of the unit during operation.
- ❑ Do not touch the electrostatic filter if the unit is equipped with one.
- ❑ Do not block the inlet or outlet of air flow to the unit.
- ❑ Do not use harsh detergents, solvents, or similar items to clean the unit. Use a soft cloth for cleaning.
- ❑ Do not touch the metal parts of the unit when removing the air filter as they are very sharp.
- ❑ Do not step on or place anything on the unit or outdoor units.
- ❑ Do not drink water drained from the unit
- ❑ Avoid direct skin contact with water drained from the unit.
- ❑ Use a firm stool or step ladder according to manufacturer procedures when cleaning or maintaining the unit.

 **CAUTION**

- ❑ Do not install or operate the unit for an extended period of time in areas of high humidity or in an environment directly exposing it to sea wind or salt spray.
  - ❑ Do not install the unit on a defective or damaged installation stand, or in an unsecure location.
- ❑ Ensure the unit is installed at a level position
- ❑ Do not install the unit where noise or air discharge created by the outdoor unit will negatively impact the environment or nearby residences.
- ❑ Do not expose skin directly to the air discharged by the unit for prolonged periods of time.
- ❑ Ensure the unit operates in areas water or other liquids.
- ❑ Ensure the drain hose is installed correctly to ensure proper water drainage.
- ❑ When lifting or transporting the unit, it is recommended that two or more people are used for this task.
- ❑ When the unit is not to be used for an extended time, disconnect the power supply or turn off the breaker.

---

## Information servicing(For flammable materials)

### 2.1 Checks to the area

Prior to beginning work on systems containing flammable refrigerants, safety checks are necessary to ensure that the risk of ignition is minimized.

For repair to the refrigerating system, the following precautions shall be complied with prior to conducting work on the system.

### 2.2 Work procedure

Work shall be undertaken under a controlled procedure so as to minimise the risk of a flammable gas or vapour being present while the work is being performed.

### 2.3 Work procedure

All maintenance staff and others working in the local area shall be instructed on the nature of work being carried out.

Work in confined spaces shall be avoided.

The area around the work space shall be sectioned off. Ensure that the conditions within the area have been made safe by control of flammable material.

### 2.4 Checking for presence of refrigerant

The area shall be checked with an appropriate refrigerant detector prior to and during work, to ensure the technician is aware of potentially flammable atmospheres.

Ensure that the leak detection equipment being used is suitable for use with flammable refrigerants, i.e. no sparking, adequately sealed or intrinsically safe.

### 2.5 Presence of fire extinguisher

If any hot work is to be conducted on the refrigeration equipment or any associated parts, appropriate fire extinguishing equipment shall be available to hand.

Have a dry powder or CO<sub>2</sub> fire extinguisher adjacent to the charging area.

### 2.6 No ignition sources

No person carrying out work in relation to a refrigeration system which involves exposing any pipe work that contains or has contained flammable refrigerant shall use any sources of ignition in such a manner that it may lead to the risk of fire or explosion.

All possible ignition sources, including cigarette smoking, should be kept sufficiently far away from the site of installation, repairing, removing and disposal, during which flammable refrigerant can possibly be released to the surrounding space.

Prior to work taking place, the area around the equipment is to be surveyed to make sure that there are no flammable hazards or ignition risks.

NO SMOKING signs shall be displayed.

### 2.7 Ventilated area

Ensure that the area is in the open or that it is adequately ventilated before breaking into the system or conducting any hot work. A degree of ventilation shall continue during the period that the work is carried out. The ventilation should safely disperse any released refrigerant and preferably expel it externally into the atmosphere.

### 2.8 Checks to the refrigeration equipment

Where electrical components are being changed, they shall be fit for the purpose and to the correct specification. At all times the manufacturer's maintenance and service guidelines shall be followed. If in doubt consult the manufacturer's technical department for assistance. The following checks shall be applied to installations using flammable refrigerants:

the charge size is in accordance with the room size within which the refrigerant containing parts are installed;

the ventilation machinery and outlets are operating adequately and are not obstructed;

if an indirect refrigerating circuit is being used, the secondary circuit shall be checked for the presence of refrigerant; marking to the equipment continues to be visible and legible.

markings and signs that are illegible shall be corrected;

refrigeration pipe or components are installed in a position where they are unlikely to be exposed to any substance which may corrode refrigerant containing components, unless the components are constructed of materials which are inherently resistant to being corroded or are suitably protected against being so corroded.

### 2.9 Checks to electrical devices

Repair and maintenance to electrical components shall include initial safety checks and component inspection procedures. If a fault exists that could compromise safety, then no electrical supply shall be connected to the circuit until it is satisfactorily dealt with. If the fault cannot be corrected immediately but it is necessary to continue operation, an adequate temporary solution shall be used. This shall be reported to the owner of the equipment so all parties are advised. Initial safety checks shall include:

---

that capacitors are discharged: this shall be done in a safe manner to avoid possibility of sparking;

that there no live electrical components and wiring are exposed while charging, recovering or purging the system;

that there is continuity of earth bonding.

## 2.10 Repairs to sealed components

During repairs to sealed components, all electrical supplies shall be disconnected from the equipment being worked upon prior to any removal of sealed covers, etc. If it is absolutely necessary to have an electrical supply to equipment during servicing, then a permanently operating form of leak detection shall be located at the most critical point to warn of a potentially hazardous situation.

Particular attention shall be paid to the following to ensure that by working on electrical components, the casing is not altered in such a way that the level of protection is affected. This shall include damage to cables, excessive number of connections, terminals not made to original specification, damage to seals, incorrect fitting of glands, etc.

Ensure that apparatus is mounted securely.

Ensure that seals or sealing materials have not degraded such that they no longer serve the purpose of preventing the ingress of flammable atmospheres. Replacement parts shall be in accordance with the manufacturer's specifications.

**NOTE:** The use of silicon sealant may inhibit the effectiveness of some types of leak detection equipment. Intrinsically safe components do not have to be isolated prior to working on them.

## 2.11 Repair to intrinsically safe components

Do not apply any permanent inductive or capacitance loads to the circuit without ensuring that this will not exceed the permissible voltage and current permitted for the equipment in use. Intrinsically safe components are the only types that can be worked on while live in the presence of a flammable atmosphere. The test apparatus shall be at the correct rating.

Replace components only with parts specified by the manufacturer. Other parts may result in the ignition of refrigerant in the atmosphere from a leak.

## 2.12 Cabling

Check that cabling will not be subject to wear, corrosion, excessive pressure, vibration, sharp edges or any other adverse environmental effects. The check

shall also take into account the effects of aging or continual vibration from sources such as compressors or fans.

## 2.13 Detection of flammable refrigerants

Under no circumstances shall potential sources of ignition be used in the searching for or detection of refrigerant leaks. A halide torch (or any other detector using a naked flame) shall not be used.

## 2.14 Leak detection methods

The following leak detection methods are deemed acceptable for systems containing flammable refrigerants. Electronic leak detectors shall be used to detect flammable refrigerants, but the sensitivity may not be adequate, or may need re-calibration. (Detection equipment shall be calibrated in a refrigerant-free area.) Ensure that the detector is not a potential source of ignition and is suitable for the refrigerant used. Leak detection equipment shall be set at a percentage of the LFL of the refrigerant and shall be calibrated to the refrigerant employed and the appropriate percentage of gas (25 % maximum) is confirmed. Leak detection fluids are suitable for use with most refrigerants but the use of detergents containing chlorine shall be avoided as the chlorine may react with the refrigerant and corrode the copper pipe-work.

If a leak is suspected, all naked flames shall be removed or extinguished.

If a leakage of refrigerant is found which requires brazing, all of the refrigerant shall be recovered from the system, or isolated (by means of shut off valves) in a part of the system remote from the leak. Oxygen free nitrogen (OFN) shall then be purged through the system both before and during the brazing process.

## 2.15 Removal and evacuation

When breaking into the refrigerant circuit to make repairs or for any other purpose, conventional procedures shall be used. However, it is important that best practice is followed since flammability is a consideration.

The following procedure shall be adhered to:

- remove refrigerant;
- purge the circuit with inert gas;
- evacuate;
- purge again with inert gas;
- open the circuit by cutting or brazing.

---

The refrigerant charge shall be recovered into the correct recovery cylinders. The system shall be flushed with OFN to render the unit safe. This process may need to be repeated several times. Compressed air or oxygen shall not be used for this task. Flushing shall be achieved by breaking the vacuum in the system with OFN and continuing to fill until the working pressure is achieved, then venting to atmosphere, and finally pulling down to a vacuum. This process shall be repeated until no refrigerant is within the system. When the final OFN charge is used, the system shall be vented down to atmospheric pressure to enable work to take place. This operation is absolutely vital if brazing operations on the pipe-work are to take place.

Ensure that the outlet for the vacuum pump is not close to any ignition sources and there is ventilation available.

## 2.16 Charging procedures

In addition to conventional charging procedures, the following requirements shall be followed:

Ensure that contamination of different refrigerants does not occur when using charging equipment. Hoses or lines shall be as short as possible to minimize the amount of refrigerant contained in them.

Cylinders shall be kept upright.

Ensure that the refrigeration system is earthed prior to charging the system with refrigerant.

Label the system when charging is complete (if not already).

Extreme care shall be taken not to overfill the refrigeration system.

Prior to recharging the system it shall be pressure tested with OFN. The system shall be leak tested on completion of charging but prior to commissioning. A follow up leak test shall be carried out prior to leaving the site.

## 2.17 Decommissioning

Before carrying out this procedure, it is essential that the technician is completely familiar with the equipment and all its detail. It is recommended good practice that all refrigerants are recovered safely. Prior to the task being carried out, an oil and refrigerant sample shall be taken.

In case analysis is required prior to re-use of reclaimed refrigerant. It is essential that electrical power is available before the task is commenced.

Become familiar with the equipment and its operation.

Isolate system electrically.

Before attempting the procedure ensure that:

mechanical handling equipment is available, if required, for handling refrigerant cylinders;

all personal protective equipment is available and being used correctly;

the recovery process is supervised at all times by a competent person;

recovery equipment and cylinders conform to the appropriate standards.

Pump down refrigerant system, if possible.

If a vacuum is not possible, make a manifold so that refrigerant can be removed from various parts of the system.

Make sure that cylinder is situated on the scales before recovery takes place.

Start the recovery machine and operate in accordance with manufacturer's instructions.

Do not overfill cylinders. (No more than 80 % volume liquid charge).

Do not exceed the maximum working pressure of the cylinder, even temporarily.

When the cylinders have been filled correctly and the process completed, make sure that the cylinders and the equipment are removed from site promptly and all isolation valves on the equipment are closed off.

Recovered refrigerant shall not be charged into another refrigeration system unless it has been cleaned and checked.

## 2.18 Labelling

Equipment shall be labelled stating that it has been de-commissioned and emptied of

refrigerant. The label shall be dated and signed. Ensure that there are labels on the equipment stating the equipment contains flammable refrigerant.

## 2.19 Recovery

When removing refrigerant from a system, either for servicing or decommissioning, it is recommended good practice that all refrigerants are removed safely.

When transferring refrigerant into cylinders, ensure that only appropriate refrigerant recovery cylinders are employed. Ensure that the correct numbers of cylinders for holding the total system charge are available. All cylinders to be used are designated for the recovered refrigerant and labelled for that refrigerant (i.e. special cylinders for the recovery of refrigerant). Cylinders shall be complete with pressure relief valve and associated shut-off valves in good working order.

---

Empty recovery cylinders are evacuated and, if possible, cooled before recovery occurs.

The recovery equipment shall be in good working order with a set of instructions concerning the equipment that is at hand and shall be suitable for the recovery of flammable refrigerants. In addition, a set of calibrated weighing scales shall be available and in good working order.

Hoses shall be complete with leak-free disconnect couplings and in good condition. Before using the recovery machine, check that it is in satisfactory working order, has been properly maintained and that any associated electrical components are sealed to prevent ignition in the event of a refrigerant release. Consult manufacturer if in doubt.

The recovered refrigerant shall be returned to the refrigerant supplier in the correct recovery cylinder, and the relevant Waste Transfer Note arranged. Do not mix refrigerants in recovery units and especially not in cylinders.

If compressors or compressor oils are to be removed, ensure that they have been evacuated to an acceptable level to make certain that flammable refrigerant does not remain within the lubricant. The evacuation process shall be carried out prior to returning the compressor to the suppliers. Only electric heating to the compressor body shall be employed to accelerate this process. When oil is drained from a system, it shall be carried out safely.

---

# Specifications

## Contents

1.	Model Reference .....	2
2.	Pipe Length and Drop Height.....	3
3.	Electrical Wiring Diagrams .....	4



---

## 1. Model Reference

Refer to the following table to determine the specific indoor and outdoor unit model.

Indoor Unit Model	Outdoor Unit Model	Capacity (Btu)	Power Supply
KEX-09KTGI	KEX-09KTGO	9k	220-240V~, 50Hz, 1 phase
KEX-12KTGI	KEX-12KTGO	12k	
KEX-18KTGI	KEX-18KTGO	18k	
KEX-24KTGI	KEX-24KTGO	24k	

## 2. Pipe Length and Drop Height

The length and elevation of connection pipe are shown in the table below. If the pipe length exceeds max pipe length, additional refrigerant should be charged to ensure nominal cooling/heating capacity.

Capacity(Btu)	Standard Length	Max Pipe Length	Max Elevation	Additional Refrigerant
9k&12k	5m (16.4ft)	25m (82.0ft)	10m (32.8ft)	12g/m (0.13oz/ft)
18k		30m (98.4ft)	20m (65.6ft)	
24k		50m (164ft)	25m (82ft)	24g/m (0.26oz/ft)

If oil flows back into the outdoor unit's compressor, this might cause liquid compression or deterioration of oil return. Oil traps in the rising gas pipe can prevent this.

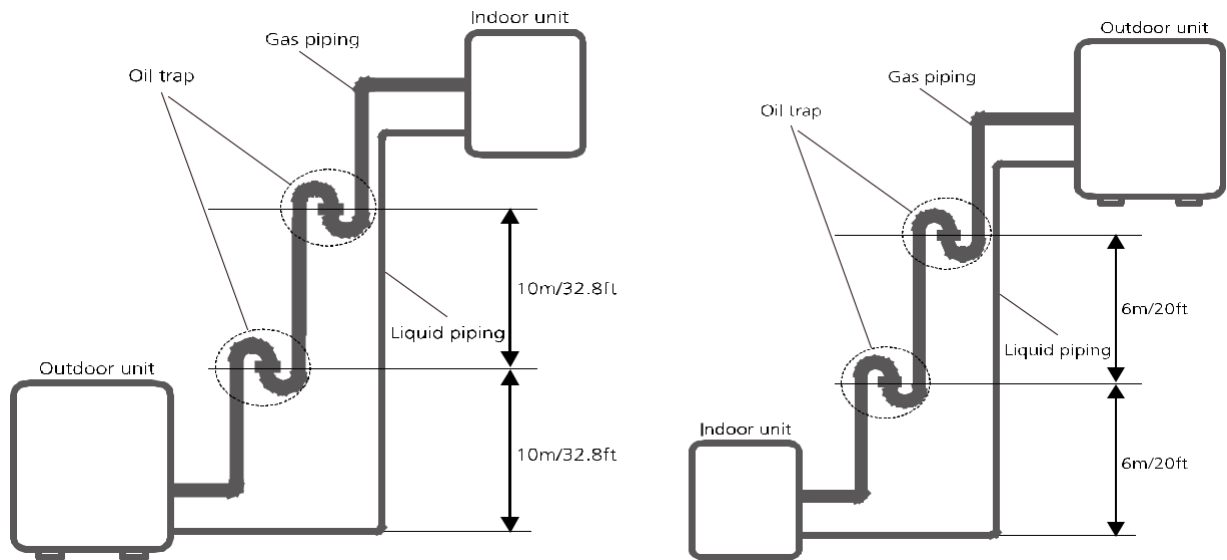

1. Indoor unit is installed higher than outdoor unit

2. Outdoor unit is installed higher than indoor unit

If indoor unit is installed higher than outdoor unit, oil trap should be set every 10m(32.8ft) of vertical distance.

If the outdoor unit is installed higher than the indoor unit, proper oil should return to the compressor along with the suction of refrigerant to keep lubrication of compressor. If the suction flow velocity drops below 7.62m/s(1500fpm (feet per minute)), oil won't return to the compressor. An oil trap should be installed every 6m(20ft) of vertical distance.

### 3. Electrical Wiring Diagrams

Indoor and outdoor unit wiring diagram

Indoor Unit		Outdoor Unit	
IDU Model	IDU Wiring Diagram	ODU Model	ODU Wiring Diagram
KEX-09KTGI	16022000020169	KEX-09KTGO	16022000019533
KEX-12KTGI		KEX-12KTGO	
KEX-18KTGI		KEX-18KTGO	
KEX-24KTGI		KEX-24KTGO	16022000B13817

Outdoor unit printed circuit board diagram

Outdoor Unit	
ODU Model	ODU Printed Circuit Board
KEX-09KTGO	17122000048121
KEX-12KTGO	
KEX-18KTGO	17122000046453
KEX-24KTGO	17122000048064

Indoor unit abbreviations

Abbreviation	Paraphrase
Y/G	Yellow-Green Conductor
ION	Positive and Negative Ion Generator
CAP	Capacitor
PLASMA	Electronic Dust Collector
L	LIVE
N	NEUTRAL
Heater	The Electric Heating Belt of Indoor Unit
T1	Indoor Room Temperature
T2	Coil Temperature of Indoor Heat Exchanger

Outdoor unit abbreviations

Abbreviation	Paraphrase
4-WAY	Gas Valve Assembly/4-WAY VALVE
AC-FAN	Alternating Current FAN
DC-FAN	Direct Current FAN
CT1	AC Current Detector
COMP	Compressor
T3	Coil Temperature of Condenser
T4	Outdoor Ambient Temperature
TH	Compressor Suction Temperature
TP	Compressor Discharge Temperature
EEV	Electronic Expansion Valve
L-PRO	Low Pressure Switch
H-PRO	High Pressure Switch

Indoor unit wiring diagram: 16022000020169

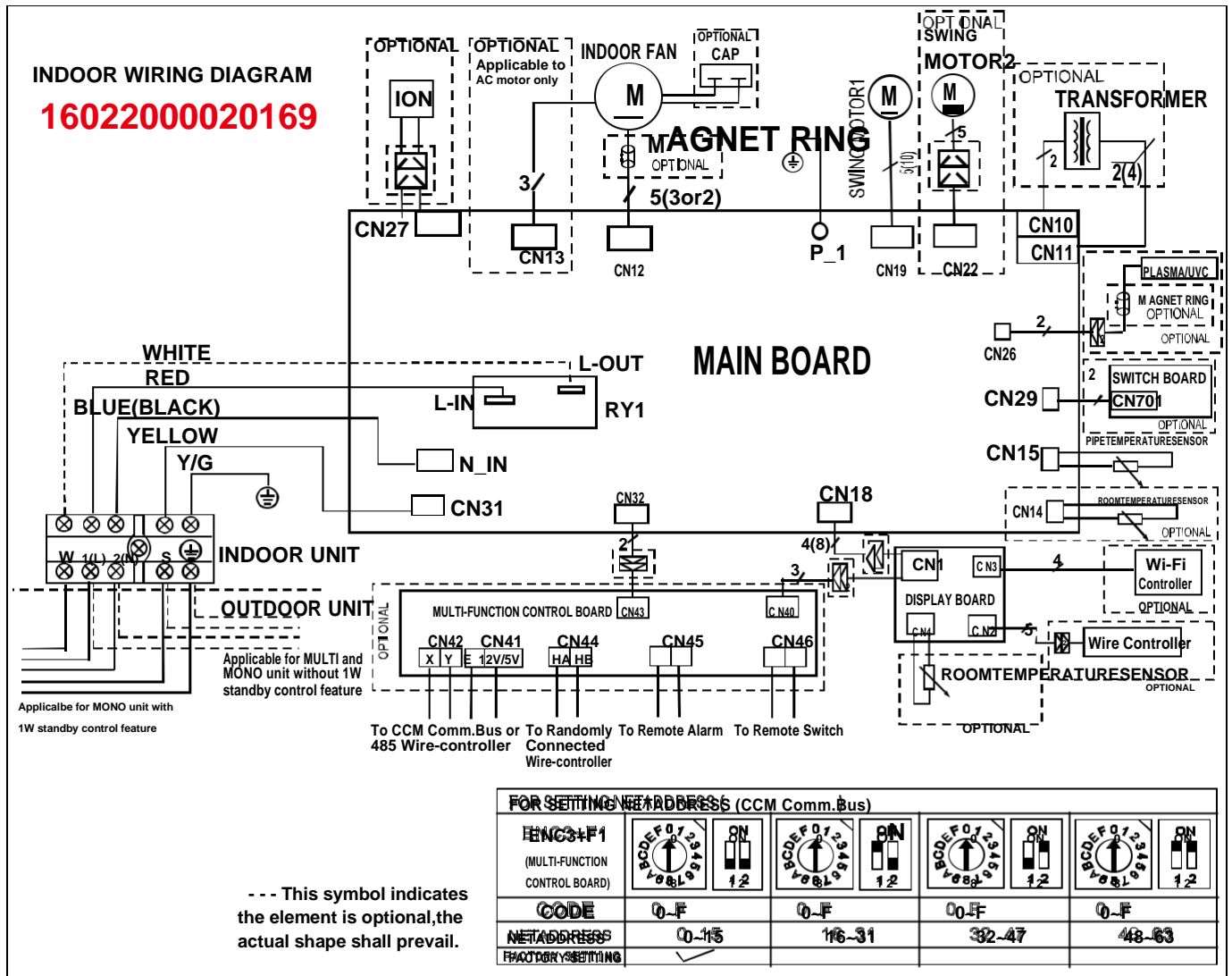

Outdoor unit wiring diagram: 16022000019533

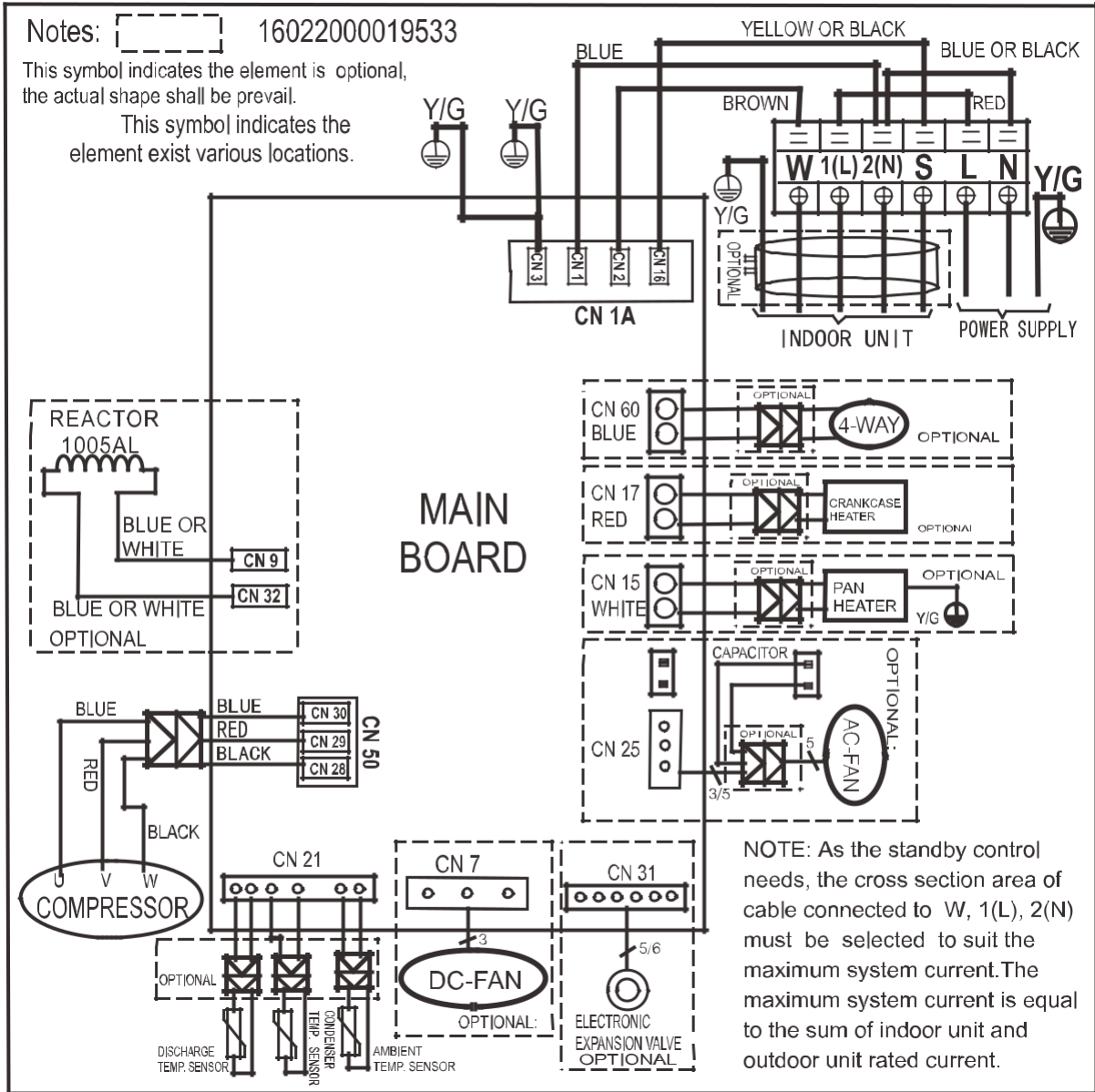

Outdoor unit wiring diagram: 16022000B13817

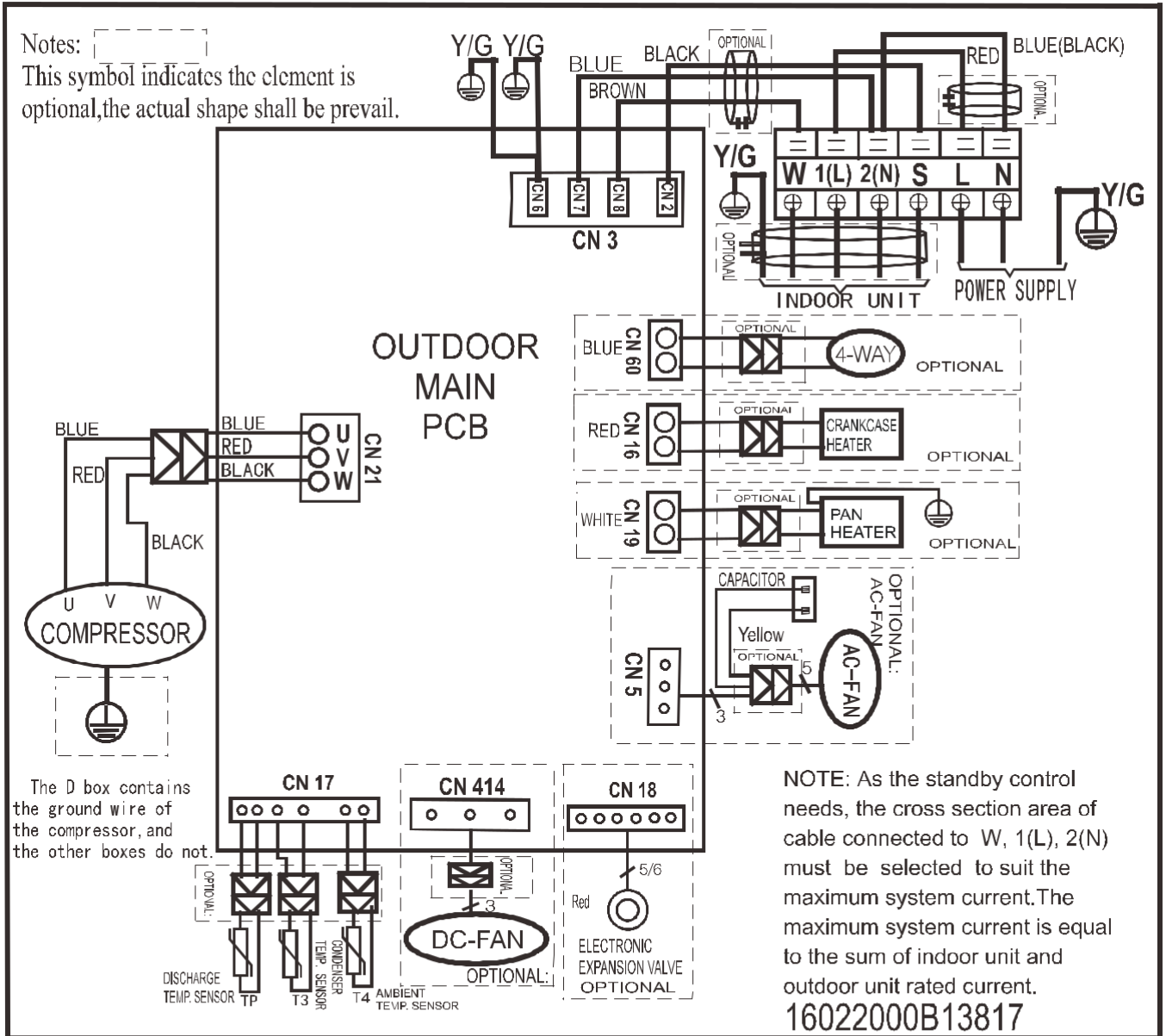

Outdoor unit printed circuit board diagram: 17122000048121, 17122000046453

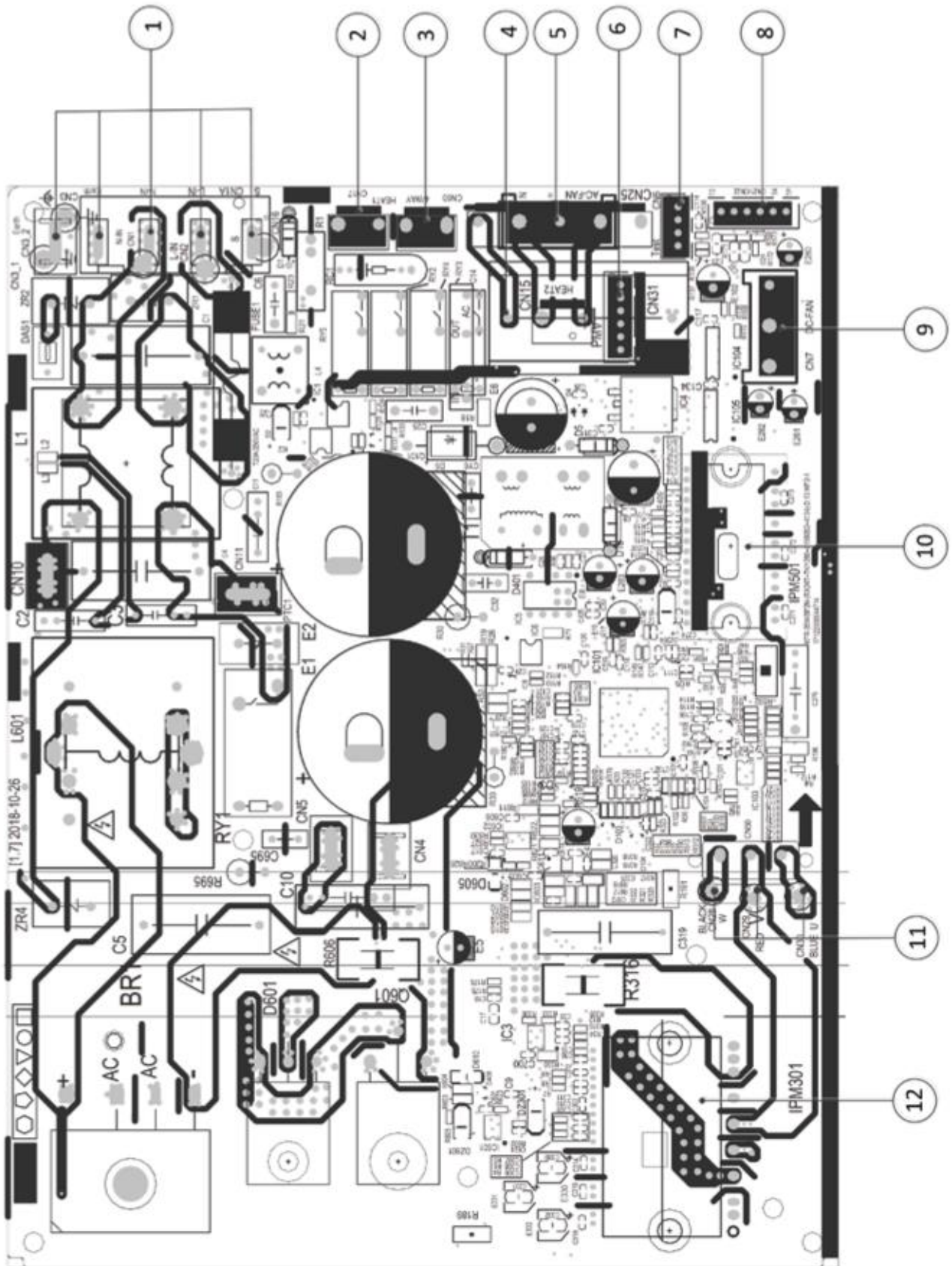



No.	Name	CN#	Meaning
1	CN1A	CN3	Earth: connect to Ground
		CN1	N_in: connect to N-line (208-230V AC input)
		CN2	L_in: connect to L-line (208-230V AC input)
		CN16	S: connect to indoor unit communication
2	HEAT1	CN17	connect to compressor heater, 208-230V AC when is ON
3	4-WAY	CN60	connect to 4 way valve, 208-230V AC when is ON.
4	HEAT2	CN15	connect to chassis heater, 208-230V AC when is ON
5	AC-FAN	CN25	connect to AC fan
6	PMV	CN31	connect to Electric Expansion Valve
7	TESTPORT	CN6	used for testing
8	TP T4 T3	CN21/CN22	connect to pipe temp. sensor T3, ambient temp. sensor T4, exhaust temp. sensor TP
9	DC-FAN	CN7	connect to DC fan
10	FAN_IPM	IPM 501	IPM for DC fan
11	W	CN28	connect to compressor
	V	CN29	0V AC (standby)
	U	CN30	10-200V AC (running)
12	COMP_IPM	IPM 301	IPM for compressor

**Note: This section is for reference only. Please take practicality as standard.**

Outdoor unit printed circuit board diagram: 17122000048064

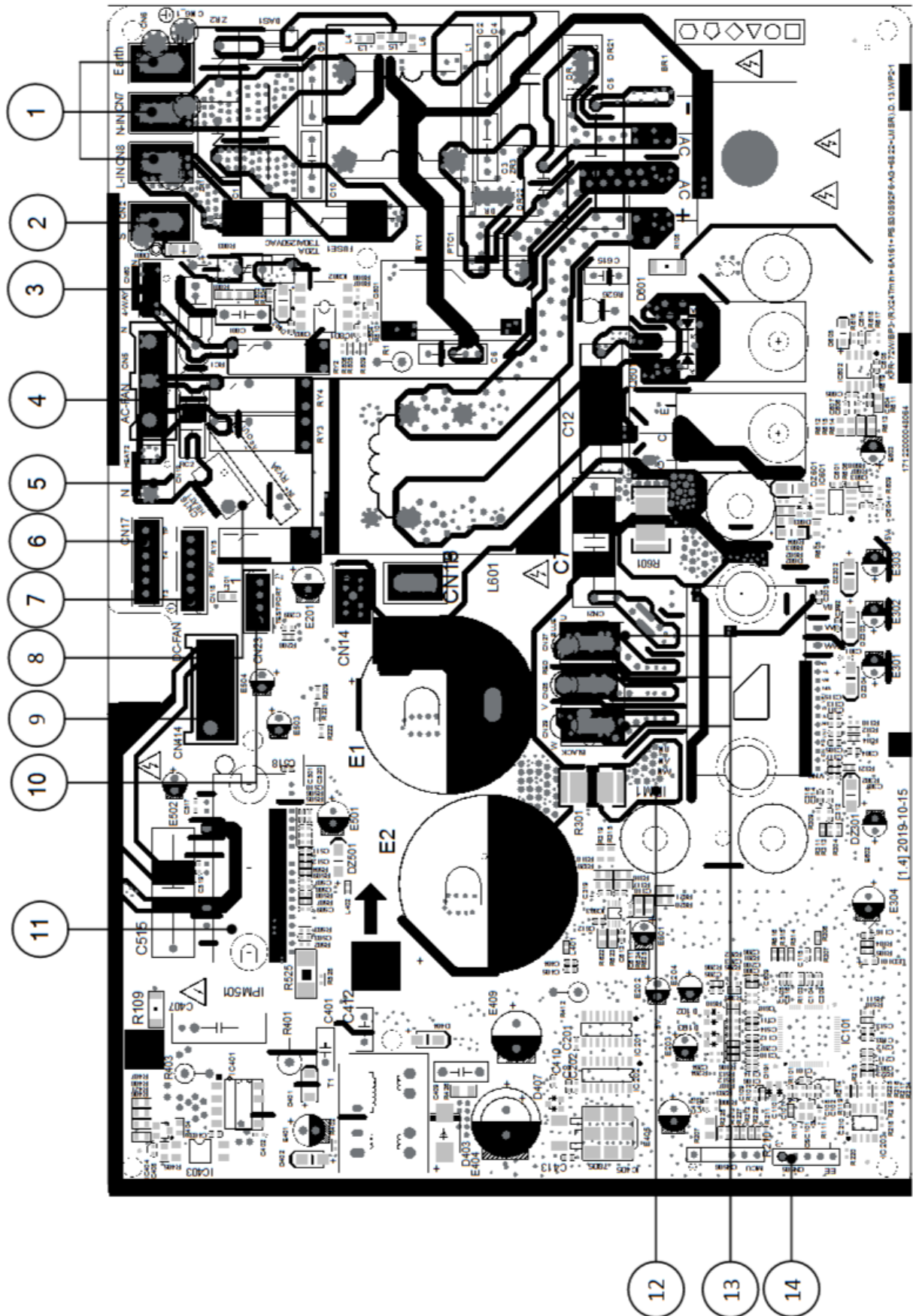

No.	Name	CN#	Meaning
1	Power Supply	CN6	Earth: connect to Ground
		CN7	N_in: connect to N-line (208-230V AC input)
		CN8	L_in: connect to L-line (208-230V AC input)
2	S	CN2	S: connect to indoor unit communication
3	4-WAY	CN60	connect to 4 way valve, 208-230V AC when is ON.
4	AC-FAN	CN5	connect to AC fan
5	HEAT2	CN19	connect to chassis heater, 208-230V AC when is ON
6	TP T4 T3	CN17	connect to pipe temp. sensor T3, ambient temp. sensor T4, exhaust temp. sensor TP
7	PMV	CN18	connect to Electric Expansion Valve
8	HEAT1	CN16	connect to compressor heater, 208-230V AC when is ON
9	DC-FAN	CN414	connect to DC fan
10	TESTPORT	CN23	used for testing
11	FAN_IPM	IPM501	IPM for DC fan
12	COMP_IPM	IPM1	IPM for compressor
13	U	CN27	connect to compressor
	V	CN28	0V AC (standby)
	W	CN29	200-300V AC (running)
14	EE_PORT	CN505	EEPROM programmer port

**Note: This section is for reference only. Please take practicality as standard.**

---

# Product Features

## Contents

<b>1. Display Function.....</b>	<b>2</b>
<b>2 Safety Features.....</b>	<b>3</b>
<b>3. Basic Functions.....</b>	<b>4</b>
3.1 Table.....	4
3.2 Abbreviation.....	5
3.3 Fan Mode.....	5
3.4 Cooling Mode.....	5
3.5 Heating Mode(Heat Pump Units).....	5
3.6 Auto-mode.....	7
3.7 Drying Mode.....	7
3.8 Forced Operation Function.....	7
3.9 Sleep Function.....	7
3.10 Auto-Restart Function.....	7
3.11 Refrigerant Leakage Detection.....	8
3.12 Ionizer/Plasma (for some models).....	8
<b>4. Optional Functions.....</b>	<b>9</b>

# 1. Display Function

Unit display functions

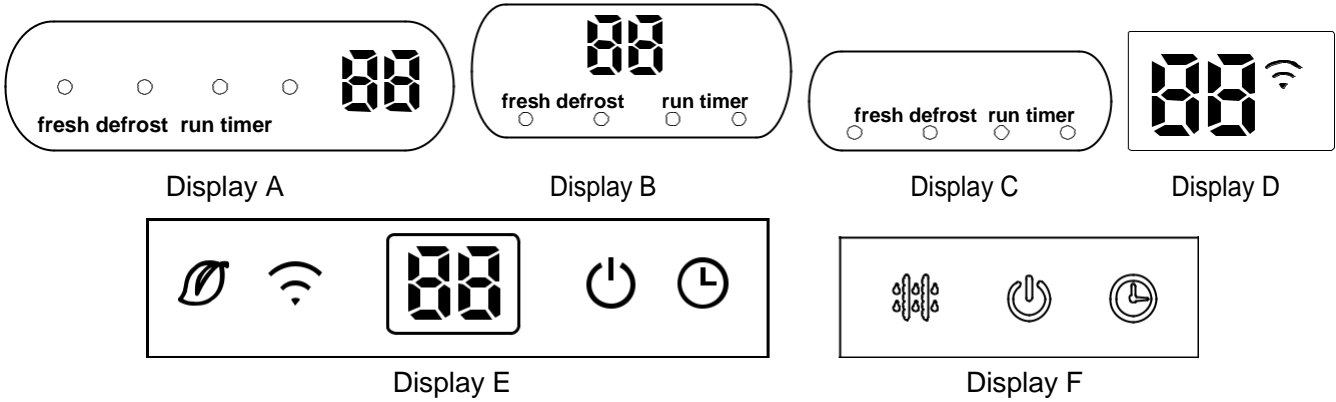

Product Features

<p>fresh or </p> <p>defrost or </p> <p>run or </p> <p>timer or </p> <p></p> <p></p>		<p>Fresh(available on select units only)</p> <p>Defrost</p> <p>When the unit is on</p> <p>When TIMER is on</p>
		WiFi control (available on select units only)
	Temperature value	Temperature
	(3s)	Activation of Timer ON, Fresh, Swing, Turbo, or Silent
	(3s)	Cancellation of Timer OFF, Fresh, Swing, Turbo, or Silent
		Defrost
		Warming in heating mode
		Self-clean (available on select units only)
	Heating in room temperature under 8°C	
gradually illuminates to  in one second intervals	ECO function (available on select units only)	

**Note:** Please select the display function according to your purchase product.

---

## 2. Safety Features

### **Compressor three-minute delay at restart**

Compressor functions are delayed for up to one minute upon the first startup of the unit, and are delayed for up to three minutes upon subsequent unit restarts.

### **Zero crossing detection error protection(Except for DC fan units)**

If AC can not detect zero crossing signal for 4 minutes or the zero crossing signal time interval is not correct, the unit will stop and the LED will display the failure. The correct zero crossing signal time interval should be between 6-13ms.

### **Automatic shutoff based on discharge temperature**

If the compressor discharge temperature exceeds a certain level for a period of time, the compressor ceases operation.

### **Automatic shutoff based on fan speed**

If the indoor fan speed registers below 300RPM for an extended period of time, the unit ceases operation and the corresponding error code is displayed on the indoor unit.

### **Inverter module protection**

The inverter module has an automatic shutoff mechanism based on the unit's current, voltage, and temperature. If automatic shutoff is initiated, the corresponding error code is displayed on the indoor unit and the unit ceases operation.

### **Indoor fan delayed operation**

When the unit starts, the louver is automatically activated and the indoor fan will operate after a period of 7 seconds.

If the unit is in heating mode, the indoor fan is regulated by the anti-cold wind function.

### **Sensor redundancy and automatic shutoff**

If one temperature sensor malfunctions, the air conditioner continues operation and displays the corresponding error code, allowing for emergency use.

When more than one temperature sensor is malfunctioning, the air conditioner ceases operation.

### **Refrigerant leakage detection**

This function is active only when cooling mode is selected. It will detect if the compressor is being damaged by refrigerant leakage or by compressor overload. This is measured using the coil temperature of evaporator T2 when the compressor is in operation.

### 3. Basic Functions

#### 3.1 Table

Functions		Cooling Mode&Heating mode		Heating Mode		Auto Mode
		Outdoor Fan Control		Defrosting Mode		
Cases		Case 1: Compressor Frequency and T4	Case 2:T4	Case 1:T3 and T4,15 min	Case 2: T3,10 min	A=2°C(3.6°F), B=-2°C(-3.6°F)
Models	KEX-09KTGI	✓		✓		✓
	KEX-12KTGI	✓		✓		✓
	KEX-18KTGI	✓		✓		✓
	KEX-24KTGI	✓		✓		✓

Note: The detailed description of case 1 or case 2 is shown in the following function sections(from 3.4 to 3.6).

## 3.2 Abbreviation

Unit element abbreviations

Abbreviation	Element
T1	Indoor room temperature
T2	Coil temperature of evaporator
T3	Coil temperature of condenser
T4	Outdoor ambient temperature
TS	Set temperature
Td	Control target temperature
TP	Compressor discharge temperature

In this manual, such as TCE1, TCE2...etc., they are well-setting parameter of EEPROM.

## 3.3 Fan Mode

When fan mode is activated:

The outdoor fan and compressor are stopped.

Temperature control is disabled and no temperature setting is displayed.

The indoor fan speed can be set to high, medium, low, or auto.

The louver operations are identical to those in cooling mode.

Auto fan: In fan-only mode, AC operates the same as auto fan in cooling mode with the temperature set at 24°C(75.2°F).

## 3.4 Cooling Mode

### 3.4.1 Compressor Control

Cooling temperature compensation( $\Delta T5$ ) is a well-setting parameter of EEPROM. It's value ranges from -2°C to 2°C. The default value is 0.

When  $T1-Ts < \Delta T5-2^{\circ}\text{C}(3.6^{\circ}\text{F})$ , the compressor ceases operation.

When  $T1-Ts > \Delta T5+3^{\circ}\text{C}(5.4^{\circ}\text{F})$ , the compressor continues operation.

When the AC is operating in mute mode, the compressor operates at a low frequency.

When the current exceeds the preset value, the current protection function activates and the compressor ceases operation.

### 3.4.2 Indoor Fan Control

In cooling mode, the indoor fan operates continuously. The fan speed can be set to high, medium, low, or

auto.

If the compressor ceases operation when the configured temperature is reached, the indoor fan motor operates at the minimum or configured speed.

The indoor fan is controlled as below:

Setting fan speed	T1-Td °C(°F)	Actual fan speed
H	※ A	H+(H-H+G)
	B	H (=H)
	C	H-(H-H-G)
M	※ D	M+(M-M+Z)
	E	M(M=M)
	F	M-(M-M-Z)
L	※ G	L+(L-L+D)
	H	L(L=L)
	I	L-(L-L-D)

- The auto fan acts as below rules:

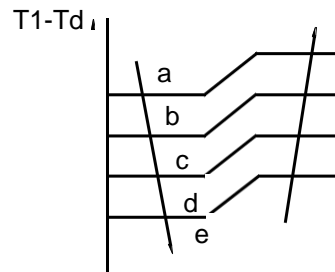

### 3.4.3 Outdoor Fan Control

#### Case 1:

The outdoor unit will be run at different fan speed according to T4 and compressor frequency.

For different outdoor units, the fan speeds are different.

#### Case 2:

The outdoor unit will be run at different fan speed according to T4.

For different outdoor units, the fan speeds are different.

### 3.4.4 Condenser Temperature Protection

When condenser temperature is more than setting value, the compressor ceases operation..

### 3.4.5 Evaporator Temperature Protection

When evaporator temperature drops below a configured value, the compressor and outdoor fan cease operation.

## 3.5 Heating Mode(Heat pump units)

### 3.5.1 Compressor Control

Heating temperature compensation( $\Delta T3$ ) is a well-setting



parameter of EEPROM. It's value ranges from -6°C to 6°C.

When  $T1-Ts > -\Delta T3$ , the compressor ceases operation.

When  $T1-Ts < -\Delta T3 - 1.5^\circ\text{C} (2.7^\circ\text{F})$ , the compressor continues operation.

When the AC is operating in mute mode, the compressor operates at a low frequency.

When the current exceeds the preset value, the current protection function activates and the compressor ceases operation.

### 3.5.2 Indoor Fan Control:

When the compressor is on, the indoor fan speed can be set to high, medium, low, or auto. And the anti-cold wind function has the priority.

Anti-cold air function

The indoor fan is controlled by the indoor temperature  $T1$  and indoor unit coil temperature  $T2$ .

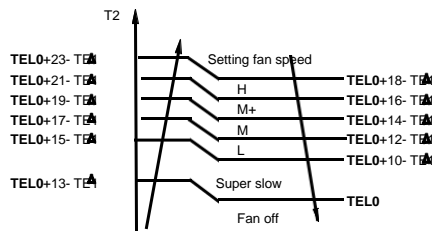

$T1 \geq 19^\circ\text{C} (66.2^\circ\text{F})$	$\Delta TE1 = 0$
$15^\circ\text{C} (59^\circ\text{F}) \leq T1 \leq 18^\circ\text{C} (64.4^\circ\text{F})$	$\Delta TE1 = 19^\circ\text{C} - T1$ ( $34.2^\circ\text{F} - T1$ )
$T1 < 15^\circ\text{C} (59^\circ\text{F})$	$\Delta TE1 = 4^\circ\text{C} (7.2^\circ\text{F})$

When the indoor temperature  $T1$  reaches the setting temperature, the compressor continues operation, the indoor fan motor runs at the minimum speed or setting speed. (The anti-cold air function is valid).

The indoor fan is controlled as below:

Setting fan speed	$T1-Td$ (°C/°F)	Actual fan speed
H	Setting fan speed	H- (H=H-G)
	Setting fan speed	H (=H)
	Setting fan speed	H+(H+=H+G)
M	Setting fan speed	M-(M-=M-Z)
	Setting fan speed	M(M=M)
	Setting fan speed	M+(M+=M+Z)
L	Setting fan speed	L-(L-=L-D)
	Setting fan speed	L(L=L)
	Setting fan speed	L+(L+=L+D)

- Auto fan action in heating mode:

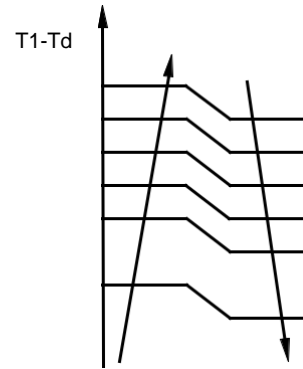

### 3.5.3 Outdoor Fan Control:

Case 1:

The outdoor unit will be run at different fan speed according to  $T4$  and compressor frequency.

For different outdoor units, the fan speeds are different.

Case 2:

The outdoor unit will be run at different fan speed according to  $T4$ .

For different outdoor units, the fan speeds are different.

### 3.5.4 Defrosting mode

Case 1:

The unit enters defrosting mode according to the temperature value of  $T3$  and  $T4$  as well as the compressor running time.

In defrosting mode, the compressor continues to run, the indoor and outdoor motor will cease operation, the defrost light of the indoor unit will turn on, and the "❄️" symbol is displayed.

If any one of the following conditions is satisfied, defrosting ends and the machine switches to normal heating mode:

$T3$  rises above  $TCDE1$ .

$T3$  maintained above  $TCDE2$  for 80 seconds.

Unit runs for 15 minutes consecutively in defrosting mode.

Case 2:

The unit enters defrosting mode according to the temperature value of  $T3$  as well as the compressor running time.

In defrosting mode, the compressor continues to run, the indoor and outdoor motor will cease operation, the defrost light of the indoor unit will turn on, and the "❄️" symbol is displayed.

If any one of the following conditions is satisfied, defrosting ends and the machine switches to normal heating mode:

T3 rises above TCDE1.

T3 maintained above TCDE2 for 80 seconds.

Unit runs for 10 minutes consecutively in defrosting mode.

### 3.5.5 Evaporator Temperature Protection

When the evaporator temperature exceeds a preset protection value, the compressor ceases operation.

### 3.6 Auto-mode

This mode can be selected with the remote controller and the setting temperature can be changed between 17°C~30°C(62°F~86°F).

In auto mode, the machine selects cooling, heating, or fan-only mode on the basis of  $\Delta T$  ( $\Delta T = T1 - TS$ ).

$\Delta T$	Running mode
$\Delta T > A$	Cooling
$B^{\circ}C \leq \Delta T \leq A$	Fan-only
$\Delta T < B$	Heating*

Heating\*: In auto mode, cooling only models run the fan

Indoor fan will run at auto fan speed.

The louver operates same as in relevant mode.

If the machine switches mode between heating and cooling, the compressor will keep stopping for certain time and then choose mode according to  $\Delta T$ .

### 3.7 Drying mode

Indoor fan speed is fixed at breeze and can't be changed. The louver angle is the same as in cooling mode.

All protections are active and the same as that in cooling mode.

### 3.8 Forced operation function

Press the AUTO/COOL button, the AC will run as below sequence:

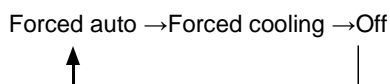

• Forced cooling mode:

The compressor and outdoor fan continue to run and the indoor fan runs at breeze speed. After running for 30 minutes, the AC will switch to auto mode with a preset temperature of 24°C(76°F).

• Forced auto mode:

Forced auto mode operates the same as normal auto mode with a preset temperature of 24°C(76°F).

The unit exits forced operation when it receives the following signals:

Switch on

Switch off

Timer on

Timer off

Changes in:

mode

fan speed

sleep mode

Follow me

Forced defrosting mode:

Press AUTO/COOL button continuously for 5s under forced cooling mode to enter this mode.

Indoor fan will stop, defrosting lamp will light on.

Quit this mode and turn off the unit when:

quit normal defrosting

turn off by RC

press AUTO/COOL button continuously for 5s again

### 3.9 Sleep function

The sleep function is available in cooling, heating, or auto mode.

The operational process for sleep mode is as follows:

When cooling, the temperature rises 1°C(2°F) (to not higher than 30°C(86°F)) every hour. After 2 hours, the temperature stops rising and the indoor fan is fixed at low speed.

When heating, the temperature decreases 1°C(2°F) (to not lower than 17°C(62.6°F)) every hour. After 2 hours, the temperature stops decreasing and the indoor fan is fixed at low speed. Anti-cold wind function takes priority.

The operating time for sleep mode is 8 hours, after which, the unit exits this mode and does not switch off.

### 3.10 Auto-Restart function

The indoor unit has an auto-restart module that allows the unit to restart automatically. The module automatically stores the current settings (not including the swing setting) and, in the case of a sudden power

---

failure, will restore those setting automatically within 3 minutes after power returns.

If the unit was in forced cooling mode, it will run in this mode for 30 minutes and turn to auto mode with temperature set to 24°C(76°F).

If there is a power failure while the unit is running, the compressor starts 3 minutes after the unit restarts. If the unit was already off before the power failure, the compressor starts 1 minute after the unit restarts.

### **3.11 Refrigerant Leakage Detection**

With this new technology, the display area will show “EC” when the outdoor unit detects refrigerant leakage.

### **3.12 Ionizer/Plasma (for some models)**

Press “Fresh” for at least 2 seconds on the remote control to enable the IONIZER function. While this function is active, the Ionizer/Plasma Dust Collector(depending on models) is energized and will help to remove pollen and impurities from the air.

---

## 4. Optional Functions

### 4.1 8°C Heating

In heating mode, the temperature can be set to as low as 8°C, preventing the indoor area from freezing if unoccupied during severe cold weather.

### 4.2 Self clean

If you press “Self Clean” when the unit is in cooling or drying mode:

For cooling models, the indoor unit will run in low fan mode for a certain time, then ceases operation.

For heat pump models, the indoor unit will run in fan-only mode, then low heat, and finally in fan-only mode.

Self Clean keeps the indoor unit dry and prevents mold growth.

When match with multi outdoor unit, this function is disabled.

### 4.3 Follow me

If you press “Follow Me” on the remote, the indoor unit will beep. This indicates the follow me function is active.

Once active, the remote control will send a signal every 3 minutes, with no beeps. The unit automatically sets the temperature according to the measurements from the remote control.

The unit will only change modes if the information from the remote control makes it necessary, not from the unit’s temperature setting.

If the unit does not receive a signal for 7 minutes or you press “Follow Me,” the function turns off.

The unit regulates temperature based on its own sensor and settings.

### 4.4 Silence

Press “Silence” on the remote control to enable the SILENCE function. While this function is active, the compressor frequency is maintained at a lower level than F3. The indoor unit will run at faint breeze, which reduces noise to the lowest possible level.

When match with multi outdoor unit, this function is disabled.

---

# Maintenance

## Contents

<b>1.</b>	<b>First Time Installation Check .....</b>	<b>2</b>
<b>2</b>	<b>Refrigerant Recharge.....</b>	<b>4</b>
<b>3</b>	<b>Re-Installation .....</b>	<b>5</b>
	<b>3.1</b> Indoor Unit.....	<b>5</b>
	<b>3.2</b> Outdoor Unit.....	<b>7</b>

# 1. First Time Installation Check

Air and moisture trapped in the refrigerant system affects the performance of the air conditioner by:

- Increasing pressure in the system.
- Increasing the operating current.
- Decreasing the cooling or heating efficiency.
- Congesting the capillary tubing due to ice build-up in the refrigerant circuit.
- Corroding the refrigerant system.

To prevent air and moisture from affecting the air conditioner's performance, the indoor unit, as well as the pipes between the indoor and outdoor unit, must be leak tested and evacuated.

### Leak test (soap water method)

Use a soft brush to apply soapy water or a neutral liquid detergent onto the indoor unit connections and outdoor unit connections. If there is gas leakage, bubbles will form on the connection.

### Air purging with vacuum pump

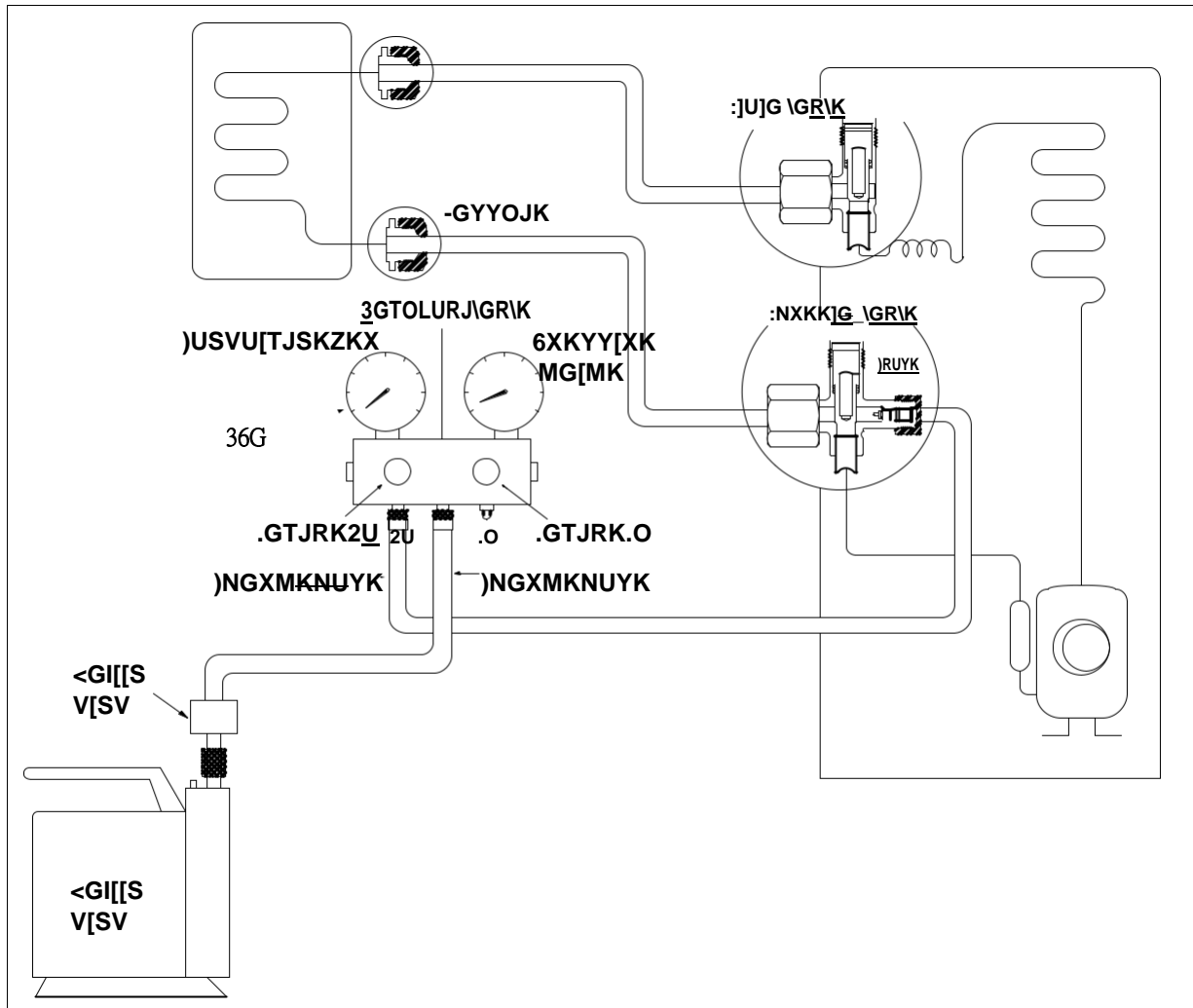

---

**Procedure:**

Tighten the flare nuts of the indoor and outdoor units, and confirm that both the 2- and 3-way valves are closed.

Connect the charge hose with the push pin of Handle Lo to the gas service port of the 3-way valve.

Connect another charge hose to the vacuum pump.

Fully open the Handle Lo manifold valve.

Using the vacuum pump, evacuate the system for 30 minutes.

Check whether the compound meter indicates -0.1 MPa (14.5 Psi).

If the meter does not indicate -0.1 MPa (14.5 Psi) after 30 minutes, continue evacuating for an additional 20 minutes.

If the pressure does not achieve -0.1 MPa (14.5 Psi) after 50 minutes, check for leakage.

If the pressure successfully reaches -0.1 MPa (14.5 Psi), fully close the Handle Lo valve, then cease vacuum pump operations.

Wait for 5 minutes then check whether the gauge needle moves after turning off the vacuum pump. If the gauge needle moves backward, check whether there is gas leakage.

Loosen the flare nut of the 3-way valve for 6 or 7 seconds and then tighten the flare nut again.

Confirm the pressure display in the pressure indicator is slightly higher than the atmospheric pressure.

Remove the charge hose from the 3-way valve.

Fully open the 2- and 3-way valves and tighten the cap of the 2- and 3-way valves.

## 2. Refrigerant Recharge

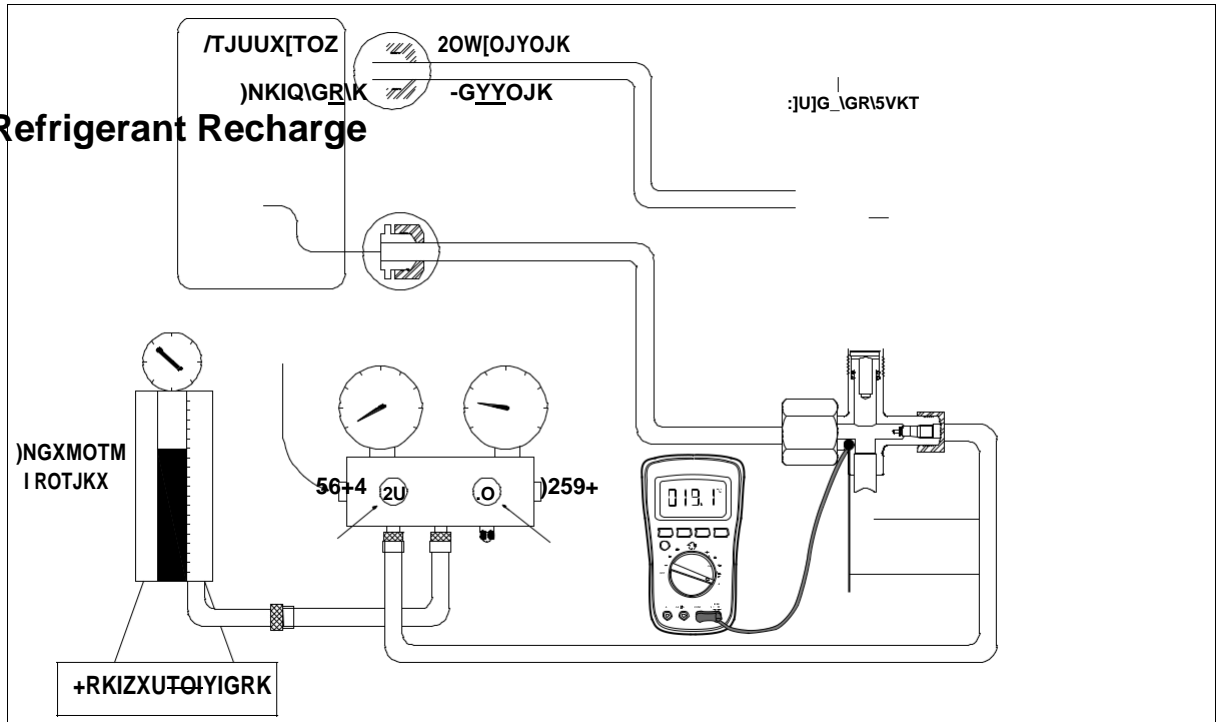



:KSV  
KXG

**Procedure:**

Close both 2- and 3-way valves.

Slightly connect the Handle Lo charge hose to the 3-way service port.

Connect the charge hose to the valve at the bottom of the cylinder.

If the refrigerant is R410A/R32, invert the cylinder to ensure a complete liquid charge.

Open the valve at the bottom of the cylinder for 5 seconds to purge the air in the charge hose, then fully tighten the charge hose with push pin Handle Lo to the service port of 3-way valve..

Place the charging cylinder onto an electronic scale and record the starting weight.

Fully open the Handle Lo manifold valve, 2- and

3-way valves.

Operate the air conditioner in cooling mode to charge the system with liquid refrigerant.

When the electronic scale displays the correct weight (refer to the gauge and the pressure of the low side to confirm, the value of pressure refers to chapter Appendix), turn off the air conditioner, then disconnect the charge hose from the 3-way service port immediately..

Mount the caps of service port and 2- and 3-way valves.

Use a torque wrench to tighten the caps to a torque of 18 N.m.

Check for gas leakage.

## 3. Re-Installation

### 3.1 Indoor Unit

#### Collecting the refrigerant into the outdoor unit

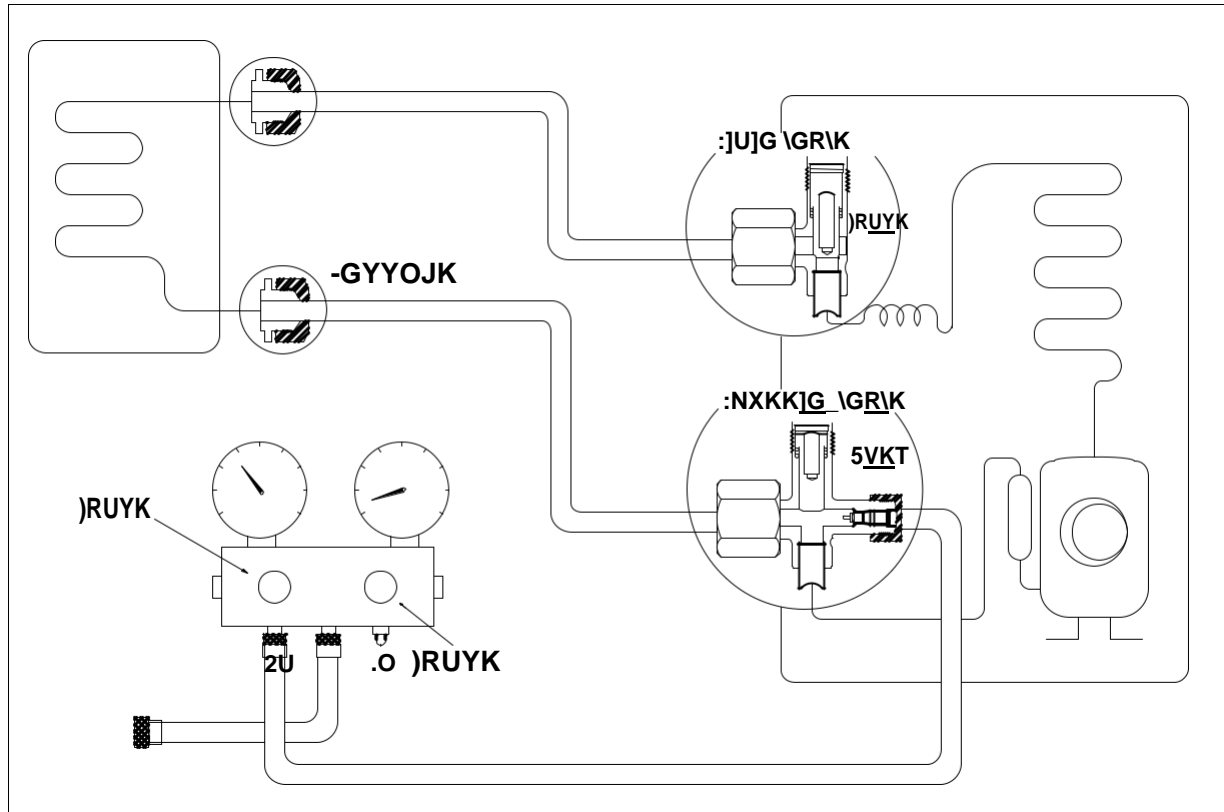

#### Procedure:

- Confirm that the 2- and 3-way valves are opened.
- Connect the charge hose with the push pin of Handle Lo to the 3-way valve's gas service port.
- Open the Handle Lo manifold valve to purge air from the charge hose for 5 seconds and then close it quickly.
- Close the 2-way valve.
- Operate the air conditioner in cooling mode.
- Cease operations when the gauge reaches 0.1 MPa (14.5 Psi).

- Close the 3-way valve so that the gauge rests between 0.3 MPa (43.5 Psi) and 0.5 MPa (72.5 Psi).
- Disconnect the charge set and mount the caps of service port and 2- and 3-way valves.
- Use a torque wrench to tighten the caps to a torque of 18 N.m.
- Check for gas leakage.

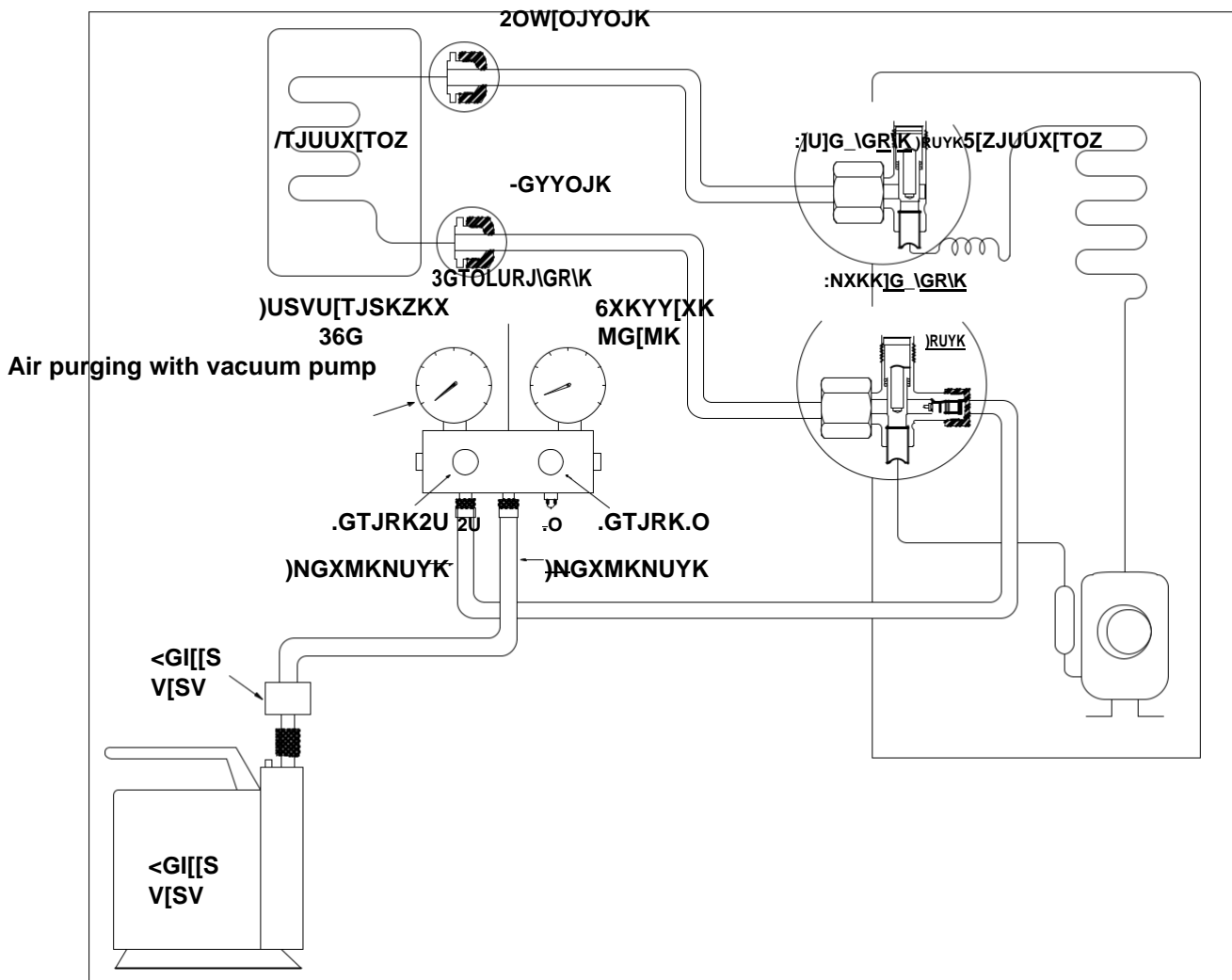

### Procedure:

Tighten the flare nuts of the indoor and outdoor units, and confirm that both the 2- and 3-way valves are closed.

Connect the charge hose with the push pin of Handle Lo to the gas service port of the 3-way valve.

Connect another charge hose to the vacuum pump.

Fully open the Handle Lo manifold valve.

Using the vacuum pump, evacuate the system for 30 minutes.

Check whether the compound meter indicates -0.1 MPa (14.5 Psi).

If the meter does not indicate -0.1 MPa (14.5 Psi) after 30 minutes, continue evacuating for an additional 20 minutes.

If the pressure does not achieve -0.1 MPa (14.5 Psi) after 50 minutes, check for leakage.

If the pressure successfully reaches -0.1 MPa (14.5 Psi), fully close the Handle Lo valve, then cease vacuum pump operations.

Wait for 5 minutes then check whether the gauge needle moves after turning off the vacuum pump. If the gauge needle moves backward, check whether there is gas leakage.

Loosen the flare nut of the 3-way valve for 6 or 7 seconds and then tighten the flare nut again.

Confirm the pressure display in the pressure indicator is slightly higher than the atmospheric pressure.

Remove the charge hose from the 3-way valve.

Fully open the 2- and 3-way valves and tighten the cap of the 2- and 3-way valves.

## 3.2 Outdoor Unit

### Evacuation for the whole system

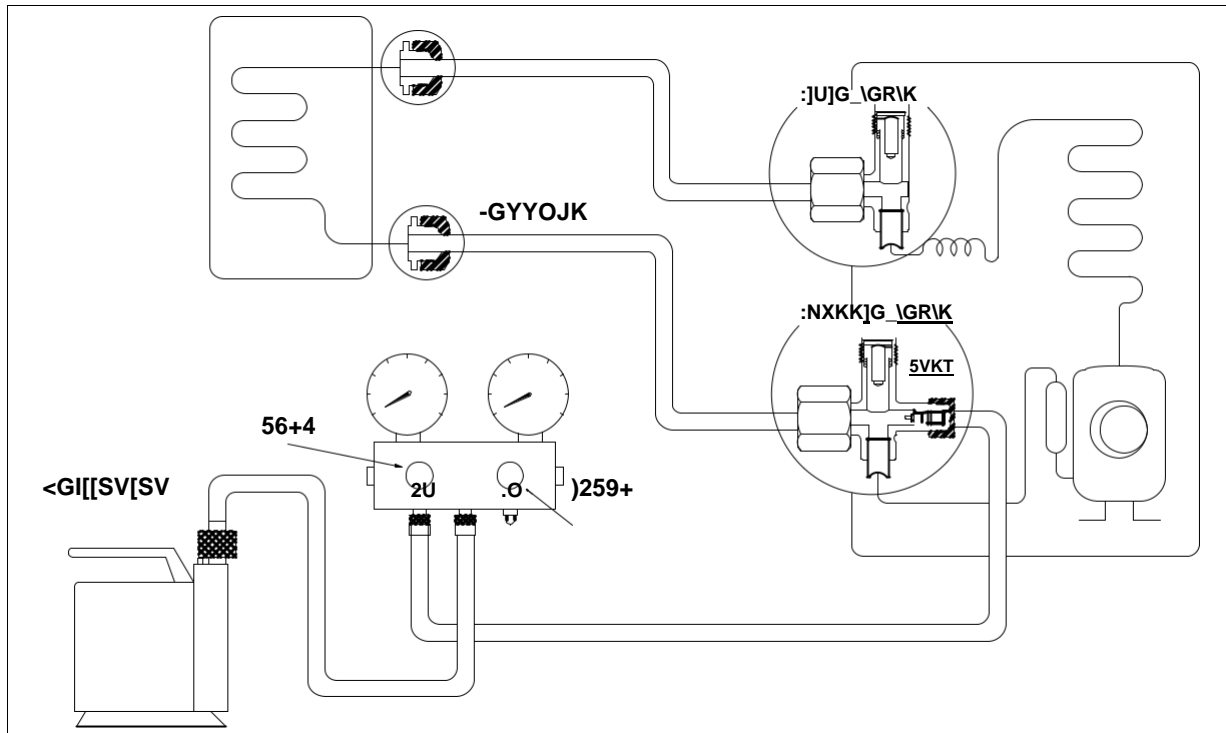

#### Procedure:

- Confirm that the 2- and 3-way valves are opened.
- Connect the vacuum pump to the 3-way valve's service port.
- Evacuate the system for approximately one hour. Confirm that the compound meter indicates -0.1 MPa (14.5Psi).
- Close the valve (Low side) on the charge set and turn off the vacuum pump.

- Wait for 5 minutes then check whether the gauge needle moves after turning off the vacuum pump. If the gauge needle moves backward, check whether there is gas leakage.
- Disconnect the charge hose from the vacuum pump.
- Mount the caps of service port and 2- and 3-way valves.
- Use a torque wrench to tighten the caps to a torque of 18 N.m.

Refrigerant charging / TJUUX[TOZ

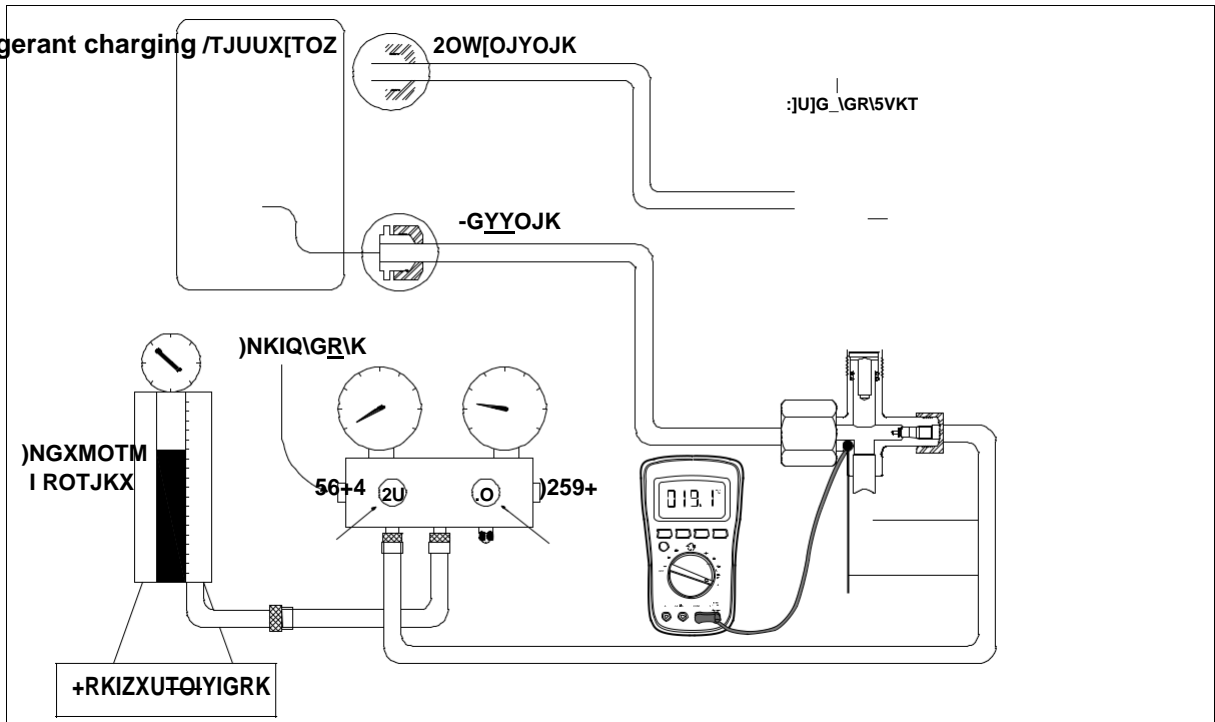

:KSV  
KXG

**Procedure:**

Close both 2- and 3-way valves.

Slightly connect the Handle Lo charge hose to the 3-way service port.

Connect the charge hose to the valve at the bottom of the cylinder.

If the refrigerant is R410A/R32, invert the cylinder to ensure a complete liquid charge.

Open the valve at the bottom of the cylinder for 5 seconds to purge the air in the charge hose, then fully tighten the charge hose with push pin Handle Lo to the service port of 3-way valve..

Place the charging cylinder onto an electronic scale and record the starting weight.

Fully open the Handle Lo manifold valve, 2- and 3-way valves.

Operate the air conditioner in cooling mode to charge the system with liquid refrigerant.

When the electronic scale displays the correct weight (refer to the gauge and the pressure of the low side to confirm, the value of pressure refers to chapter Appendix), turn off the air conditioner, then disconnect the charge hose from the 3-way service port immediately..

Mount the caps of service port and 2- and 3-way valves.

Use a torque wrench to tighten the caps to a torque of 18 N.m.

Check for gas leakage.

**Note: 1. Mechanical connectors used indoors shall comply with local regulations.**

**When mechanical connectors are reused indoors, sealing parts shall be renewed. When flared joints are reused indoors, the flare part shall be re-fabricated.**

---

# Indoor Unit Disassembly

## Contents

1. Dimension .....	2
2. Indoor Unit Disassembly .....	3
2.1 Front Panel .....	3
2.2 Electrical parts .....	8
2.3 Evaporator .....	12
2.4 Fan motor and fan .....	13
2.5 Step motor .....	14

## 1. Dimension

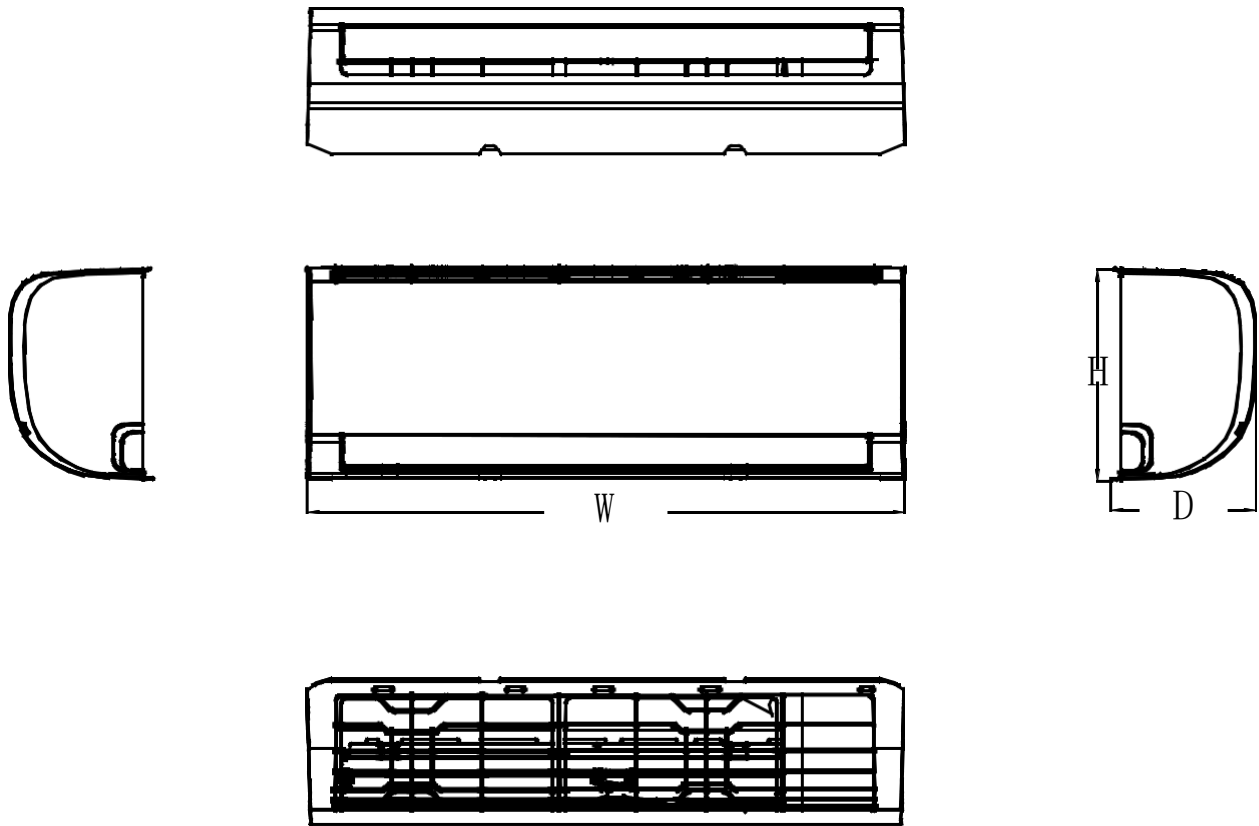

Capacity	Body Code	W(mm)	D(mm)	H(mm)
5K~11K	A	715	194	285
9K~14K	B	805	194	285
17K~18K	C	957	213	302
18K~24K	D	1040	220	327



## 2. Disassembly

### 2.1 Indoor unit

#### Front Panel

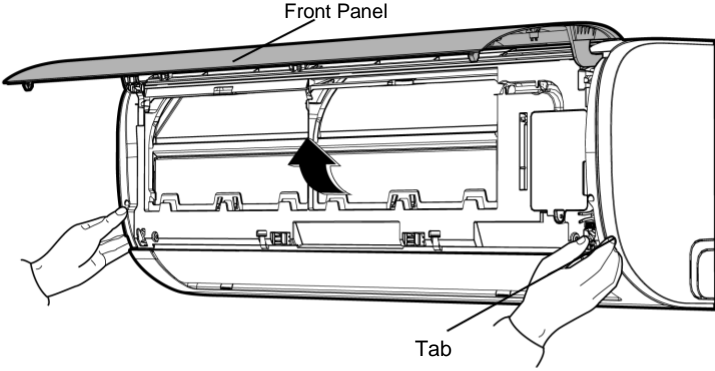
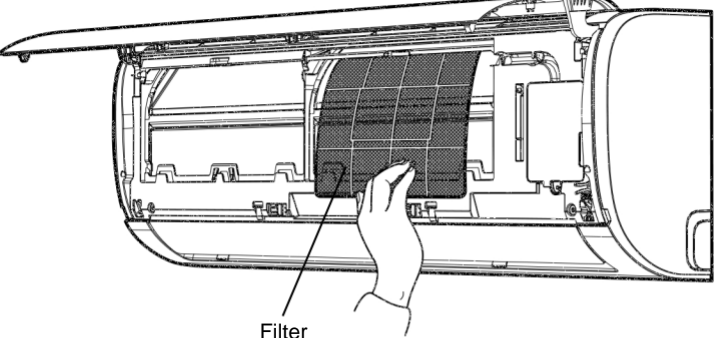
Procedure	Illustration
<p>Hold the front panel by the tabs on the both sides and lift it (see CJ_AF_001).</p>	 <p><b>CJ_AF_001</b></p>
<p>Push up the bottom of an air filter, and then pull it out downwards (see CJ_AF_002).</p>	 <p><b>CJ_AF_002</b></p>

Note: This section is for reference only. Actual unit appearance may vary.

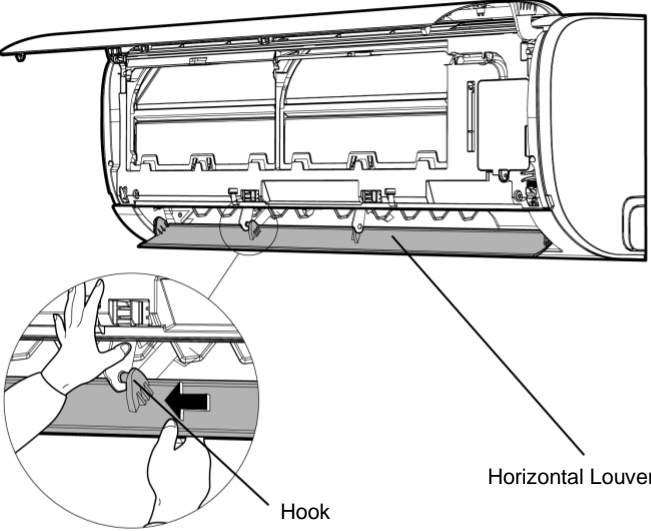
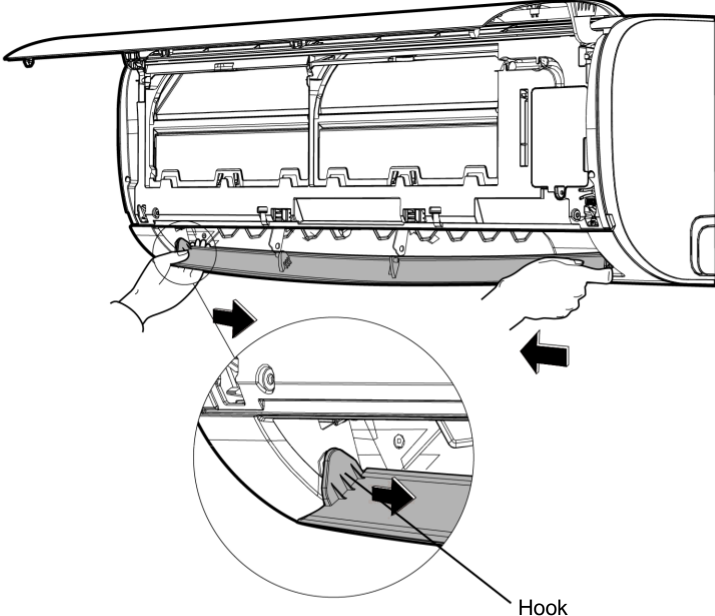
Procedure	Illustration
<p>Open the horizontal louver and push the hook towards left to open it (see CJ_AF_003).</p>	 <p style="text-align: center;"><b>CJ_AF_003</b></p>
<p>Bend the horizontal louver lightly by both hands to loosen the hooks, then remove the horizontal louver (see CJ_AF_004).</p>	 <p style="text-align: center;"><b>CJ_AF_004</b></p>

**Note:** This section is for reference only. Actual unit appearance may vary.

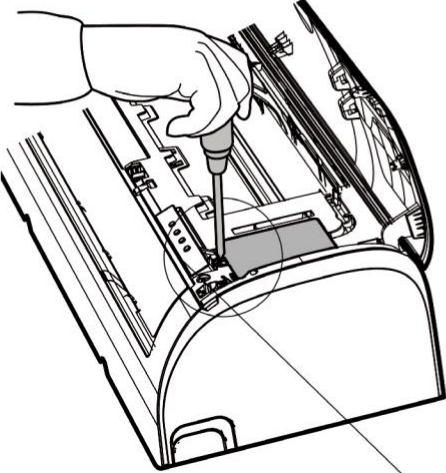
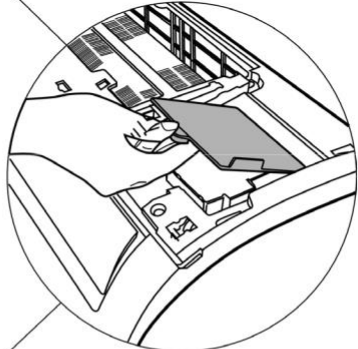
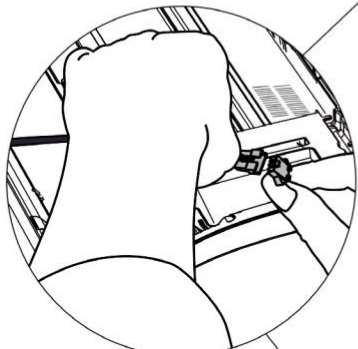
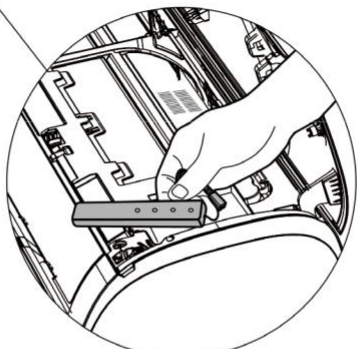
Procedure	Illustration
<p>Remove 1 screw and then remove the electrical cover(see CJ_AF_005-1 and CJ_AF_005-2).</p>	 <p>CJ_AF_005-1</p>  <p>CJ_AF_005-2</p>
<p>Disconnect the connector for display board(see CJ_AF_005-3) .</p>	 <p>CJ_AF_005-3</p>
<p>Remove the display board(see CJ_AF_005-4).</p>	 <p>CJ_AF_005-4</p> <p>CJ_AF_005</p>

**Note:** This section is for reference only. Actual unit appearance may vary.

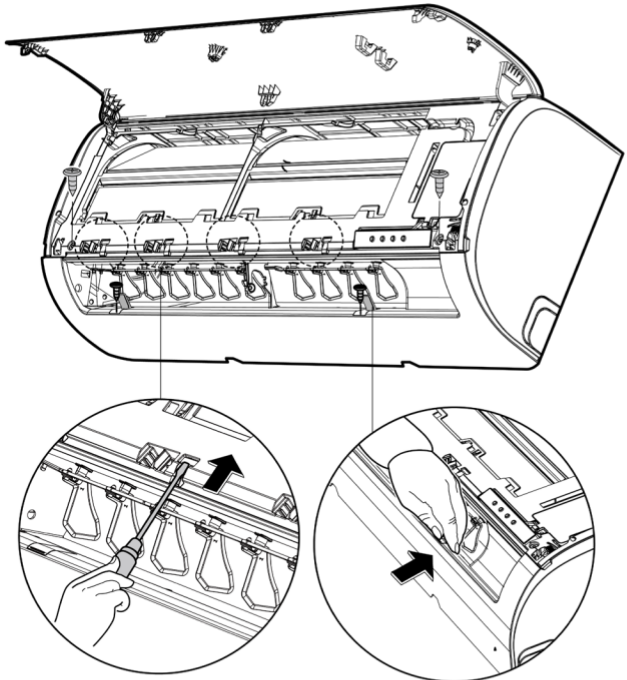
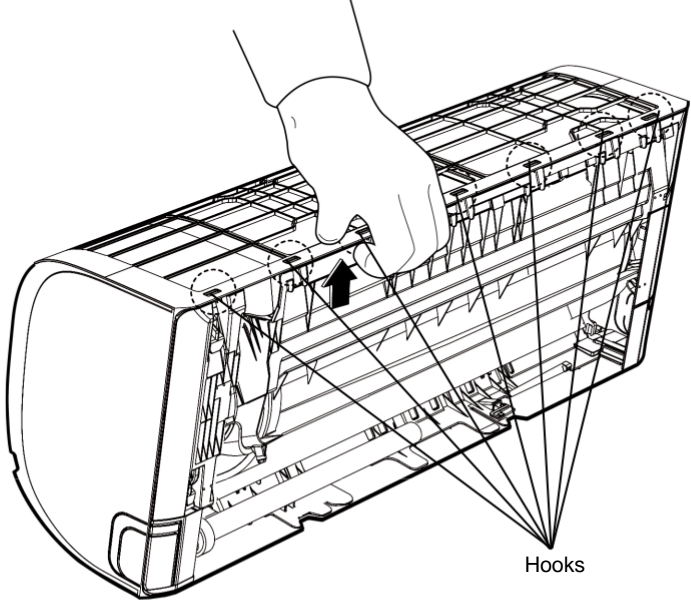
Procedure	Illustration
<p>Open the screw caps(2) and the remove the screws(see CJ_AF_006).</p> <p>Release the 4 hooks.</p>	 <p>The illustration shows the top cover of the indoor unit with its lid open. Four screws are indicated by dashed circles and arrows. Below the main view are two circular callouts: the left one shows a hand using a screwdriver to remove a screw, and the right one shows a hand releasing a hook. The label 'CJ_AF_006' is centered below these callouts.</p>
<p>10) Release the seven hooks in the back (see CJ_AF_007).</p>	 <p>The illustration shows the back of the indoor unit with a hand reaching in to release a hook. An arrow points to the hook being released. A label 'Hooks' with lines pointing to several hooks is located at the bottom right. The label 'CJ_AF_007' is centered below the diagram.</p>

**Note:** This section is for reference only. Actual unit appearance may vary.

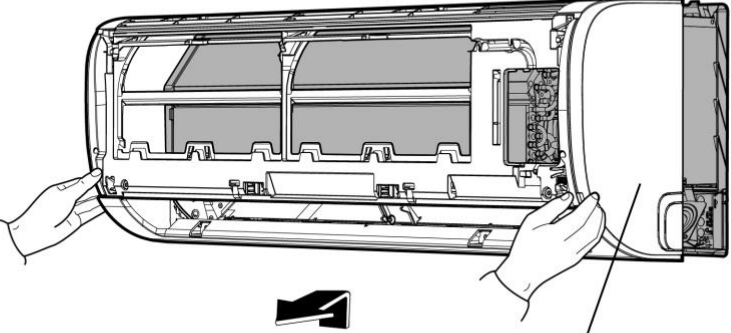
Procedure	Illustration
<p>11) Pull out the panel frame while pushing the hook through a clearance between the panel frame and the heat exchanger (see CJ_AF_008).</p>	 <p data-bbox="887 725 1082 761"><b>CJ_AF_008</b></p> <p data-bbox="1177 734 1286 757">Panel Frame</p>

**Note:** This section is for reference only. Actual unit appearance may vary.

## Electrical parts

**Note:** Remove the front panel (refer to 1. Front panel) before disassembling electrical parts.

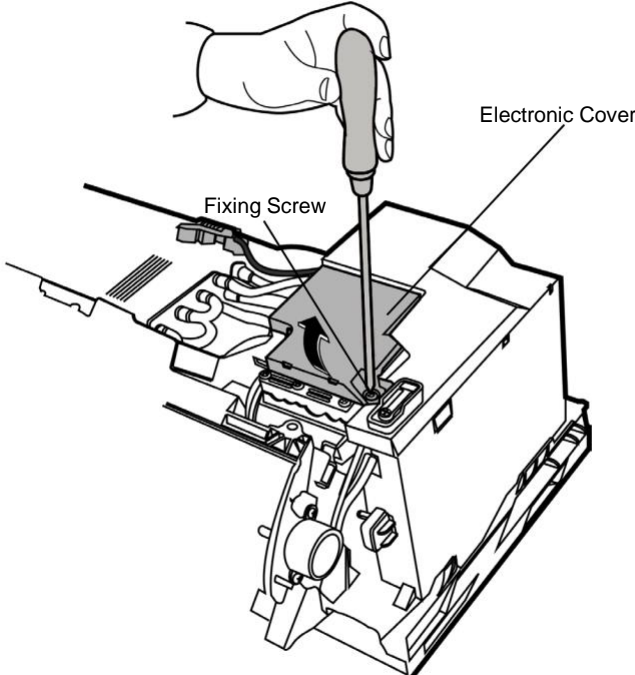
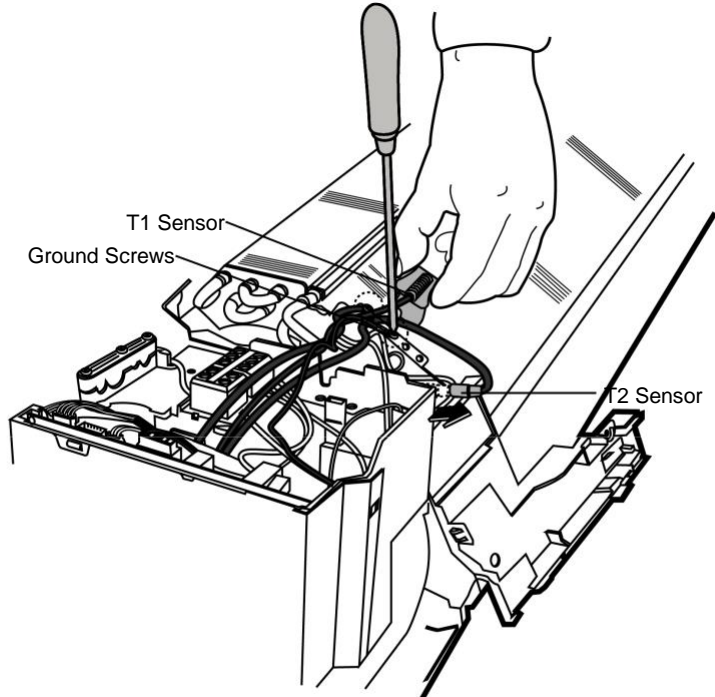
Procedure	Illustration
<p>Remove the fixing screw and then remove the cover of electronic box and the terminal cover (see CJ_AF_009).</p>	 <p>CJ_AF_009</p>
<p>Pull out the room temperature sensor (T1) and the coil temperature sensor (T2) (see CJ_AF_010).</p> <p>Remove the two screws used for the ground connection (see CJ_AF_010).</p>	 <p>CJ_AF_010</p>

**Note:** This section is for reference only. Actual unit appearance may vary.

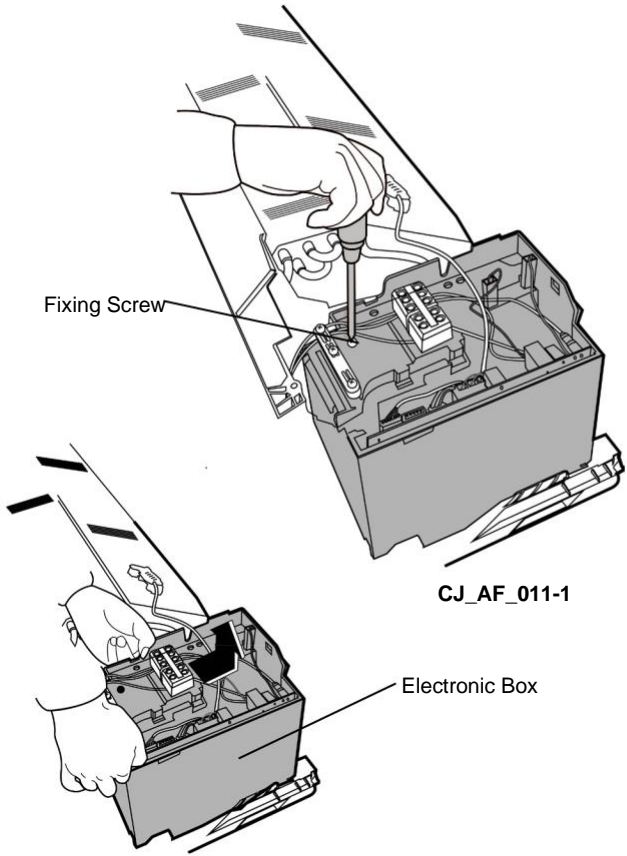
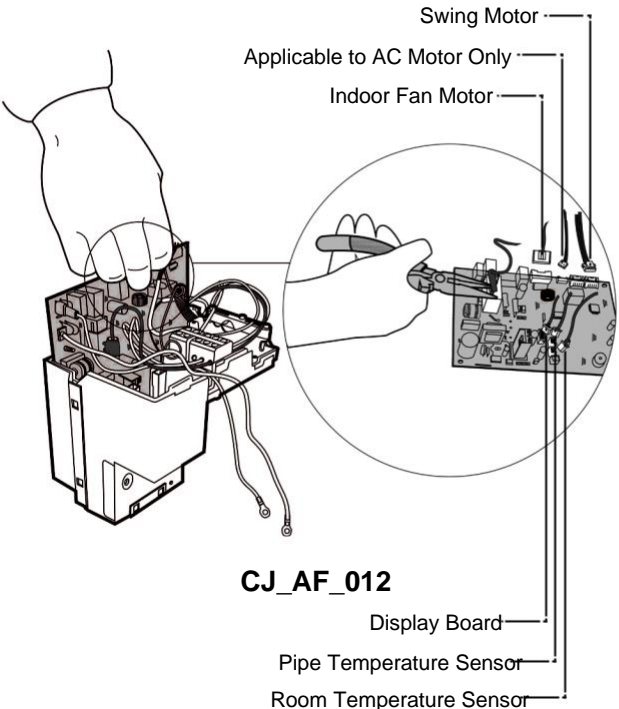
Procedure	Illustration
<p>Remove the fixing screw (see CJ_AF_011-1).</p> <p>Pull out the Electrical control box along the direction indicated in right image. to remove it (CJ_AF_011-2).</p>	 <p>Fixing Screw</p> <p>CJ_AF_011-1</p> <p>Electronic Box</p> <p>CJ_AF_011-2</p>
<p>Disconnect the wires. Then remove the electronic main board (CJ_AF_012).</p>	 <p>Swing Motor</p> <p>Applicable to AC Motor Only</p> <p>Indoor Fan Motor</p> <p>CJ_AF_012</p> <p>Display Board</p> <p>Pipe Temperature Sensor</p> <p>Room Temperature Sensor</p>

**Note:** This section is for reference only. Actual unit appearance may vary.

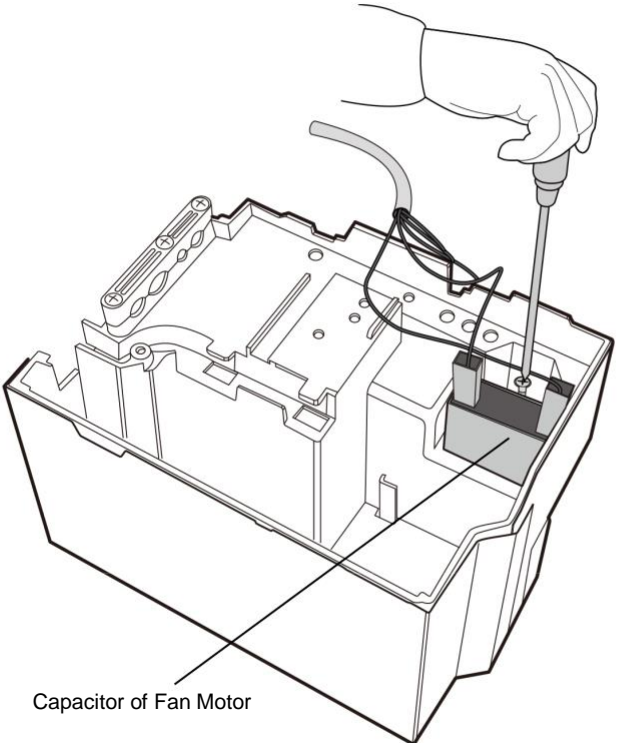

Procedure	Illustration
<p>Remove the fixing screw, then remove the capacitor of fan motor (see CJ_AF_013).</p>	 <p data-bbox="933 1086 1093 1131"><b>CJ_AF_013</b></p>

**Note:** This section is for reference only. Actual unit appearance may vary.



## Evaporator

**Note:** Remove the front panel and electrical parts (refer to 1. Front panel and 2. Electrical parts) before disassembling evaporator.

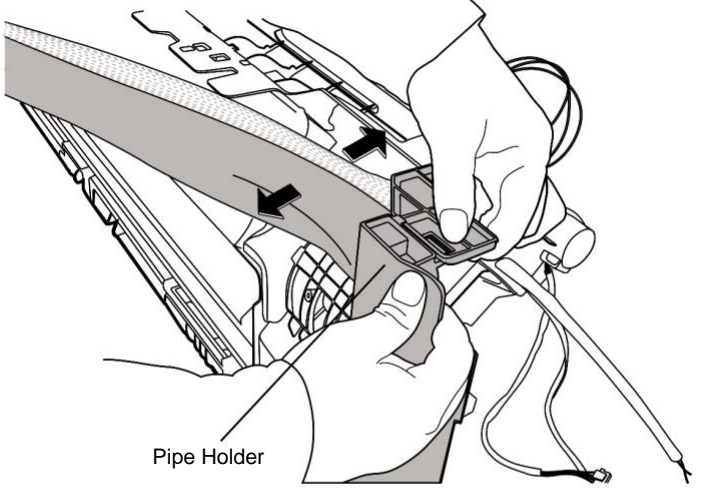
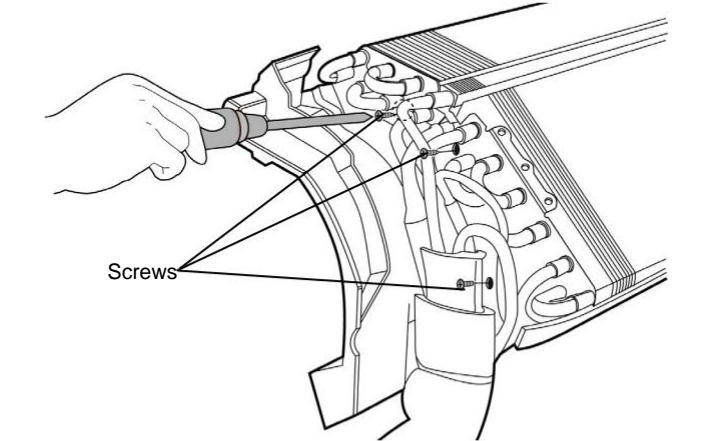
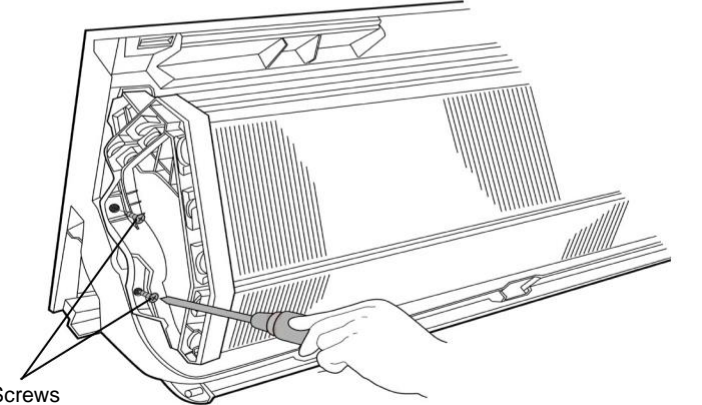
Procedure	Illustration
<p>Disassemble the pipe holder located at the rear of the unit (see CJ_AF_014).</p>	 <p>Pipe Holder</p> <p><b>CJ_AF_014</b></p>
<p>Remove the screws on the evaporator located at the fixed plate (see CJ_AF_015).</p>	 <p>Screws</p> <p><b>CJ_AF_015</b></p>
<p>Remove the two screws on the evaporator located at the base of the bearing side (see CJ_AF_016).</p>	 <p>Screws</p> <p><b>CJ_AF_016</b></p>

**Note:** This section is for reference only. Actual unit appearance may vary.

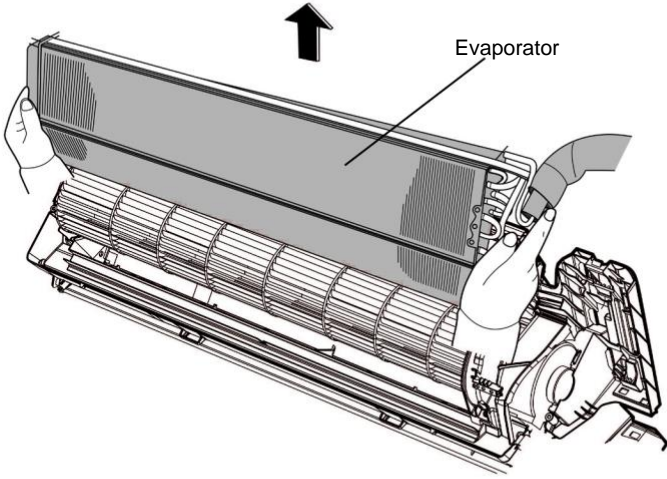
Procedure	Illustration
4) Pull out the evaporator (see CJ_AF_017).	 <p data-bbox="970 862 1125 896">CJ_AF_017</p>

Note: This section is for reference only. Actual unit appearance may vary.

## Fan motor and fan

**Note:** Remove the front panel, electrical parts and evaporator (refer to 1. Front panel, 2. Electrical parts, and 3. Evaporator). before disassembling fan motor and fan.

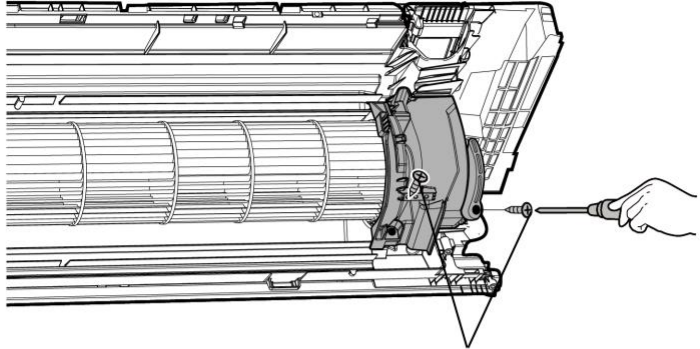
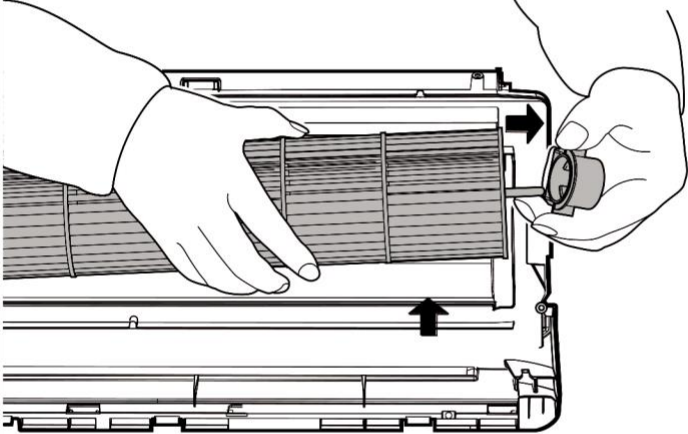
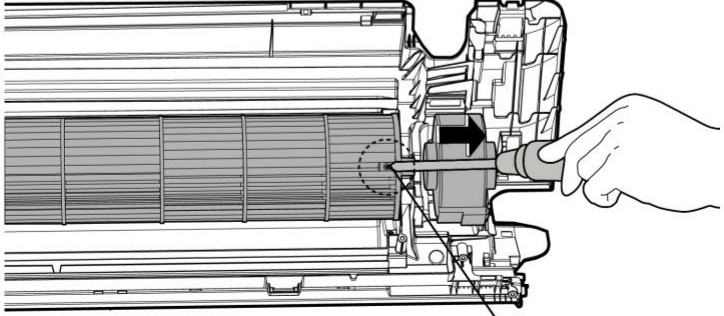
Procedure	Illustration
<p>Remove the two screws and remove the fixing board of the fan motor (see CJ_AF_018).</p>	 <p>Screws</p> <p>CJ_AF_018</p>
<p>Remove the Bearing sleeve(see CJ_AF_019).</p>	 <p>CJ_AF_019</p>
<p>Remove the fixing screw (see CJ_AF_020).</p> <p>Pull out the fan motor and fan assembly from the side.</p>	 <p>Fixing Screw</p> <p>CJ_AF_020</p>

**Note:** This section is for reference only. Actual unit appearance may vary.

### Step motor

**Note:** Remove the front panel and electrical parts (refer to 1. Front panel, 2. Electrical parts) before disassembling step motor.

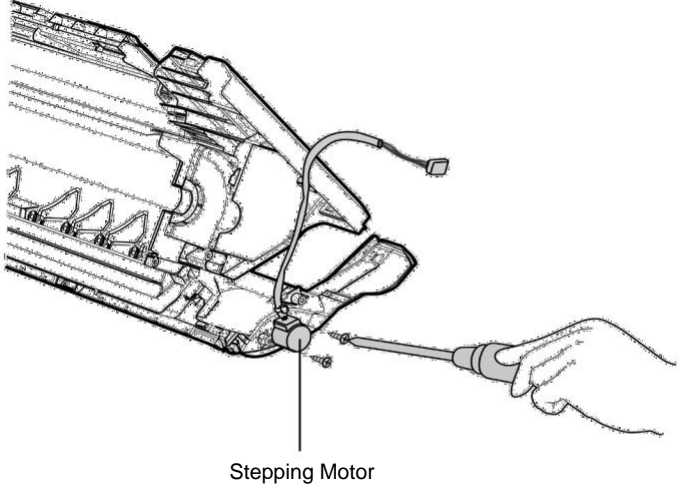
Procedure	Illustration
Remove the two screws, then remove the stepping motor (see CJ_AF_021).	 <p data-bbox="932 913 1078 936">Stepping Motor</p> <p data-bbox="959 1010 1106 1032">CJ_AF_021</p>

**Note:** This section is for reference only. Actual unit appearance may vary.

---

# Outdoor Unit Disassembly

## Contents

<b>1. Outdoor Unit Table</b> .....	<b>2</b>
<b>2. Dimension</b> .....	<b>3</b>
<b>3. Outdoor Unit Disassembly</b> .....	<b>6</b>
3.1 Panel Plate .....	6
3.2 Electrical Parts .....	15
3.3 Fan Assembly .....	19
3.4 Fan Motor .....	20
3.5 Sound blanket .....	21
3.6 Four-way valve .....	22
3.7 Compressor .....	23

---

## 1. Outdoor Unit Disassembly

### 1.1 Outdoor Unit Table

Outdoor Unit Model	Panel Plate	PCB Board
KWX-09HRGO	X130	PCB board 9
KWX-12HRGO	X130	PCB board 9
KWX-18HRGO	X330	PCB board 9
KWX-24HRGO	X430	PCB board 6

## 2. Dimension

### Panel Plate X130

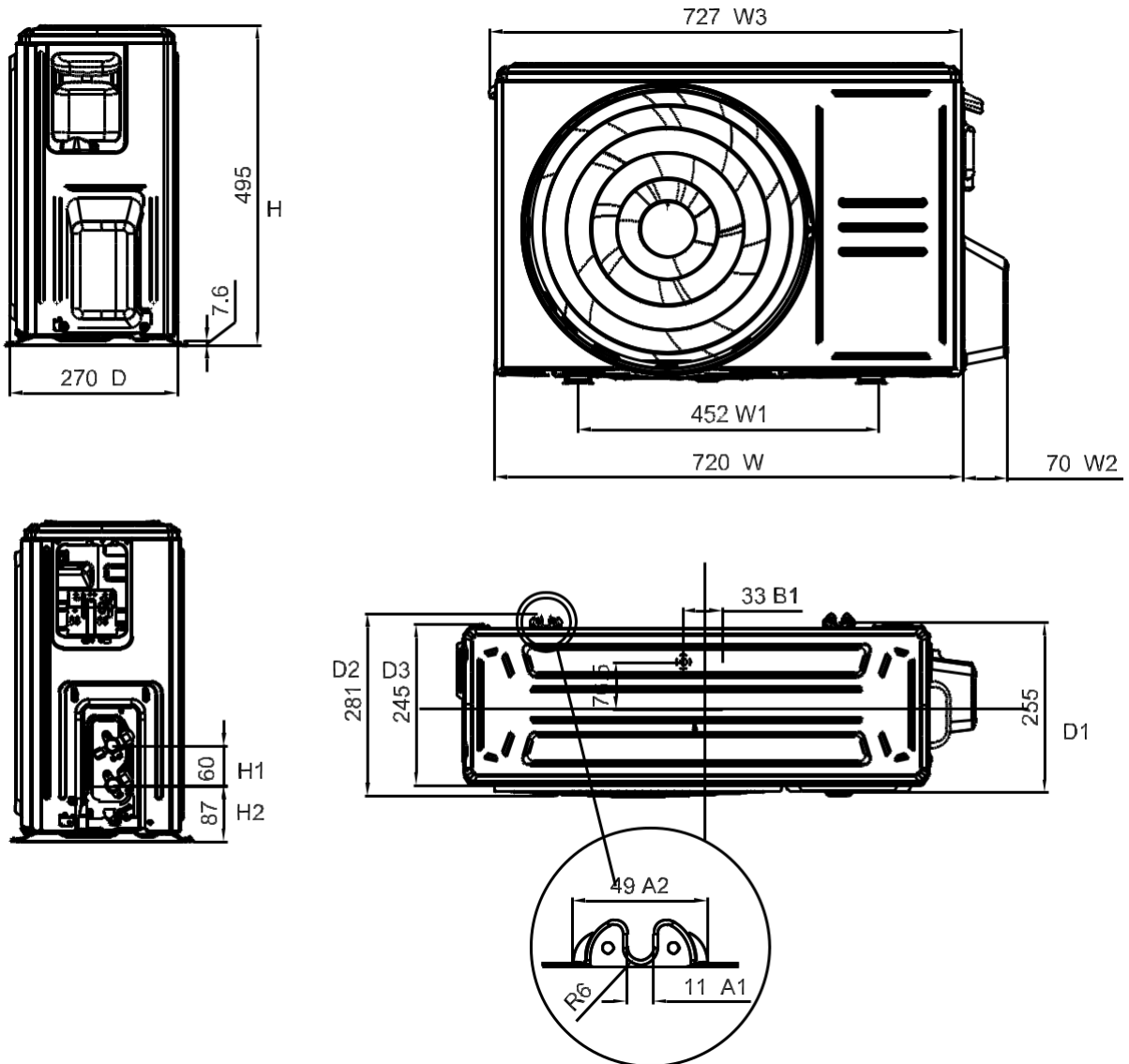

## 2. Panel Plate X330

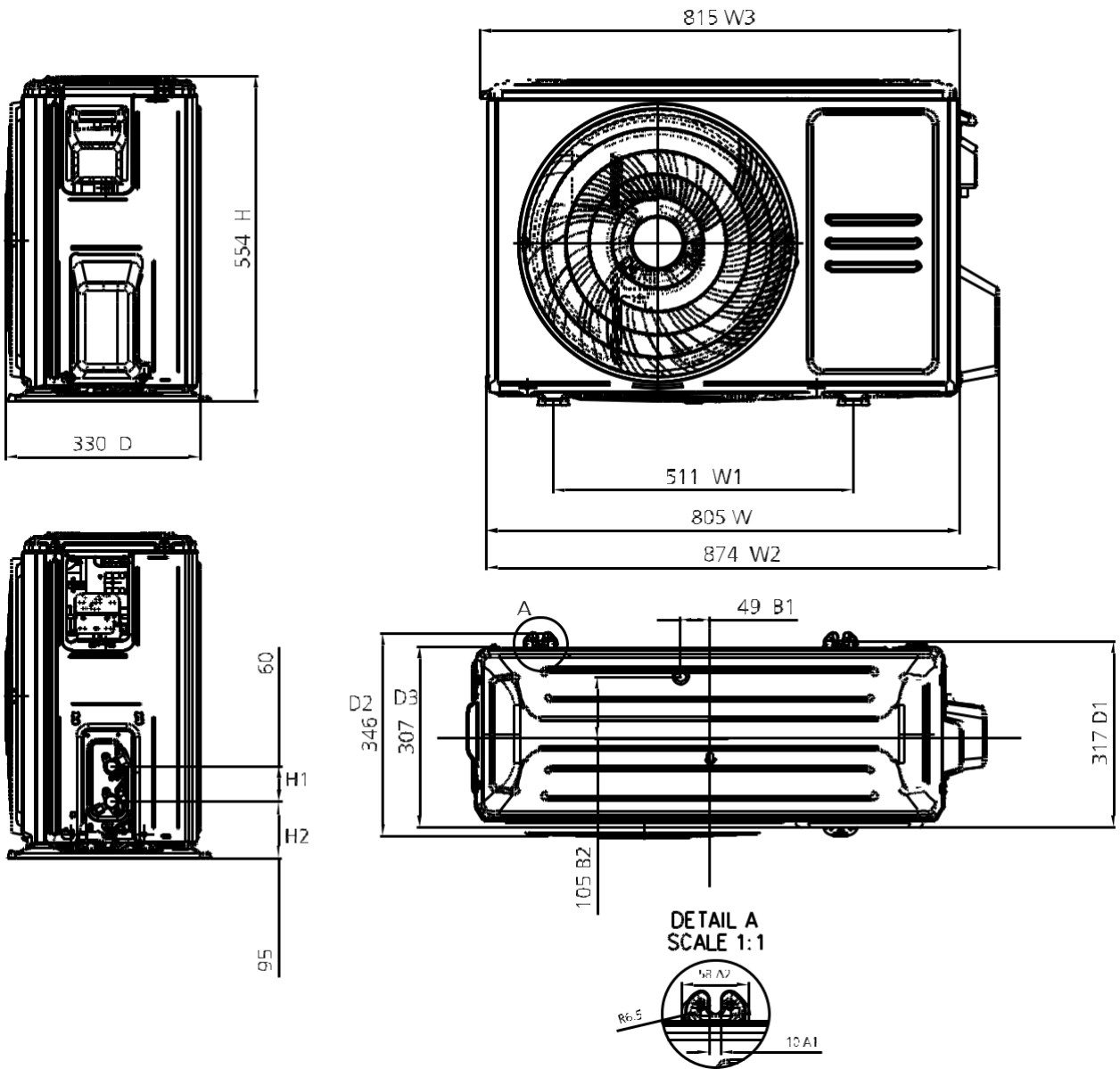



### 3. Panel Plate X430

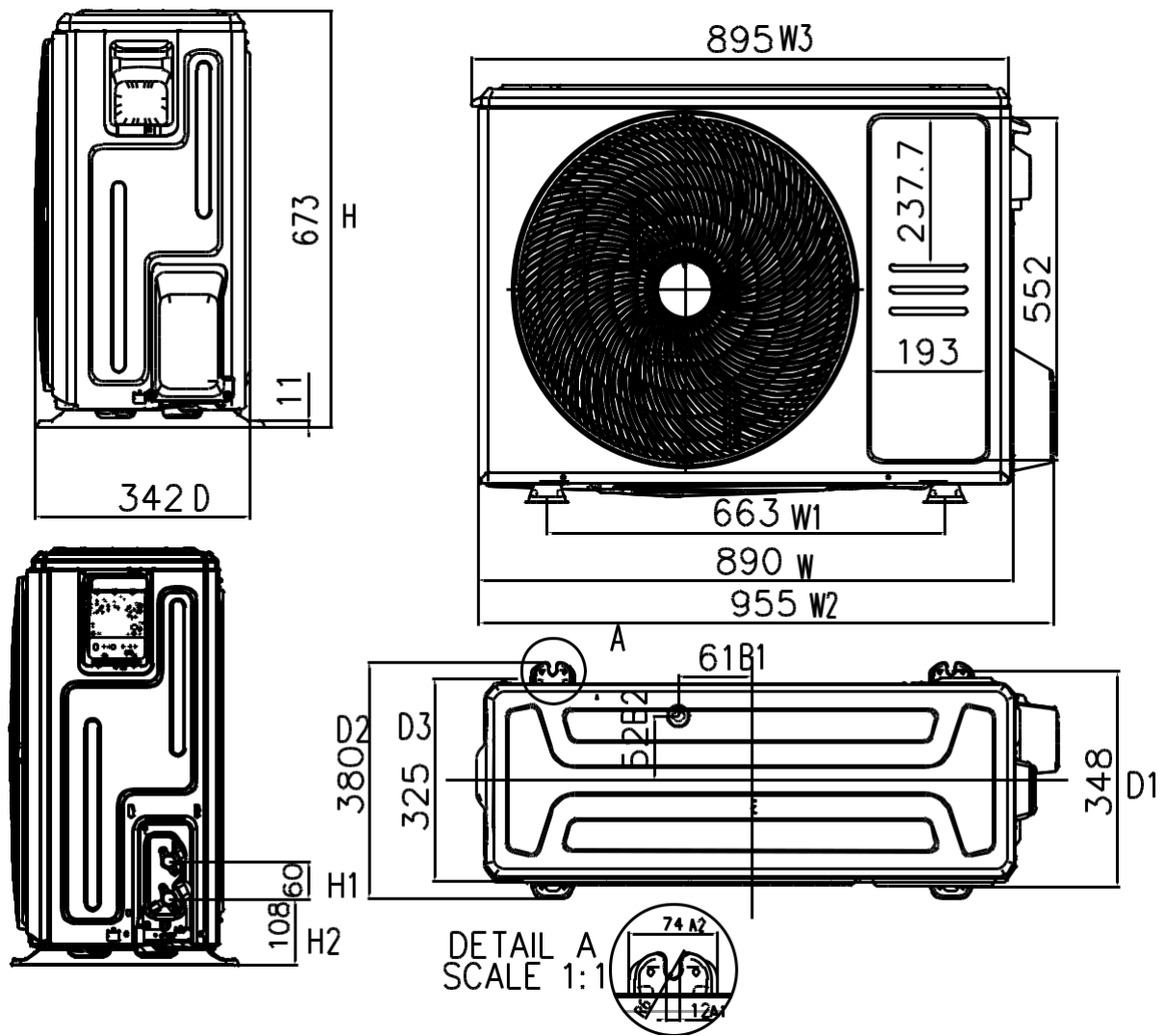

### 3. Outdoor Unit Disassembly

#### 3.1 Panel Plate

##### 1. X130

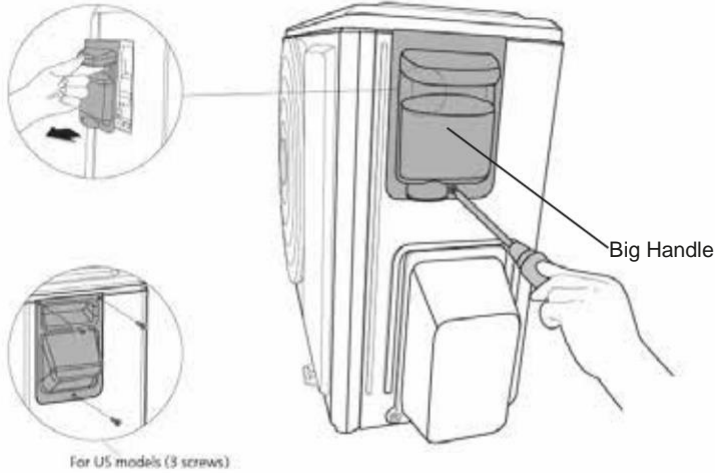
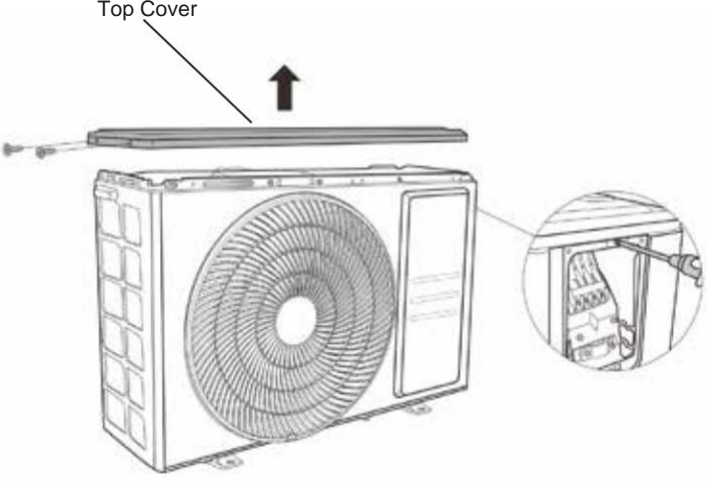
Procedure	Illustration
<p>Turn off the air conditioner and the power breaker.</p> <p>Remove the screw of the big handle and then remove the big handle (1 screw) (see CJ_X130_001).</p>	 <p style="text-align: center;"><b>CJ_X130_001</b></p>
<p>Remove the screws of the top cover and then remove the top cover (3 screws). One of the screws is located underneath the big handle (see CJ_X130_002).</p>	 <p style="text-align: center;"><b>CJ_X130_002</b></p>

**Note:** This section is for reference only. Actual unit appearance may vary.

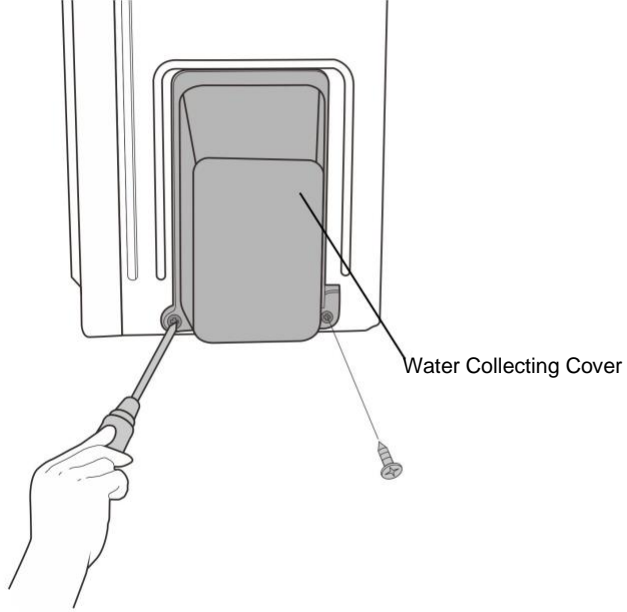
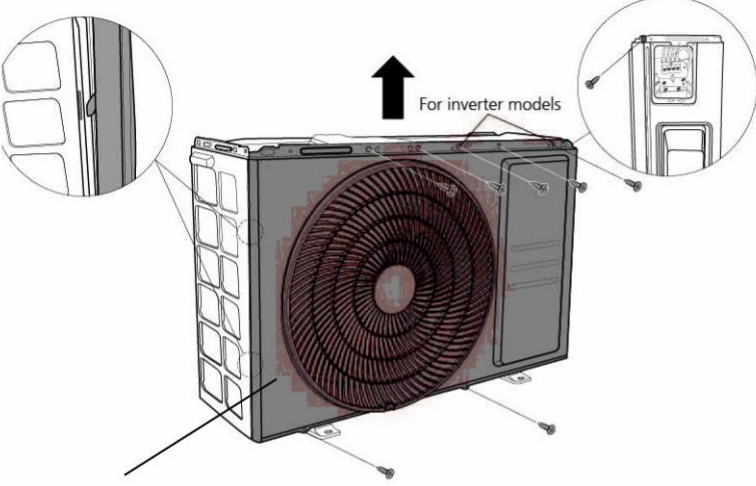
Procedure	Illustration
<p>Remove the screws of water collecting cover and then remove the water collecting cover (2 screws) (see CJ_X130_003).</p>	 <p style="text-align: center;"><b>CJ_X130_003</b></p>
<p>Remove the screws of the front panel and then remove the front panel (6 screws(onoff models) or 8 screws(inverter models) (see CJ_X130_004).</p>	 <p style="text-align: center;"><b>CJ_X130_004</b></p>

**Note:** This section is for reference only. Actual unit appearance may vary.

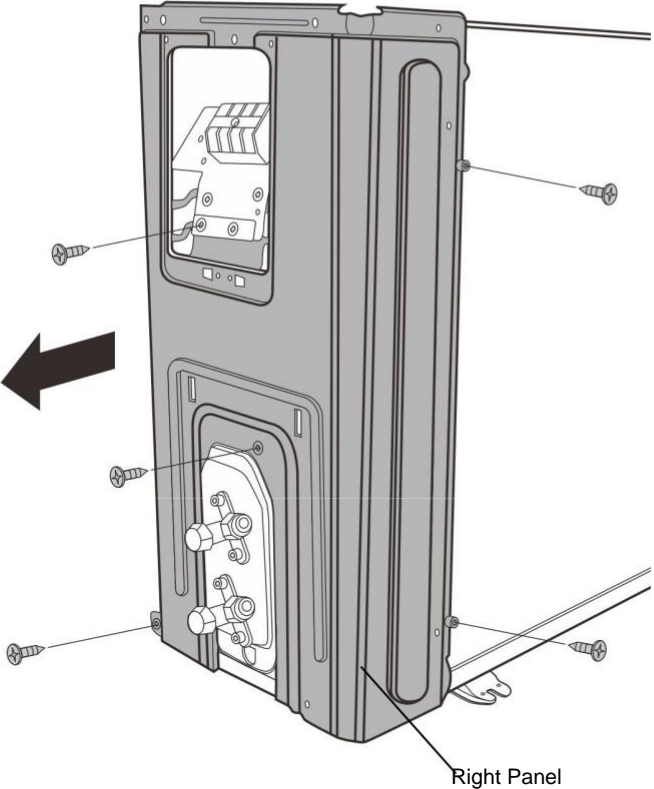
Procedure	Illustration
<p>Remove the screws of the right panel and then remove the right panel (5 screws) (see CJ_X130_005).</p>	 <p style="text-align: center;"><b>CJ_X130_005</b></p>

**Note:** This section is for reference only. Actual unit appearance may vary.

## 2. X330

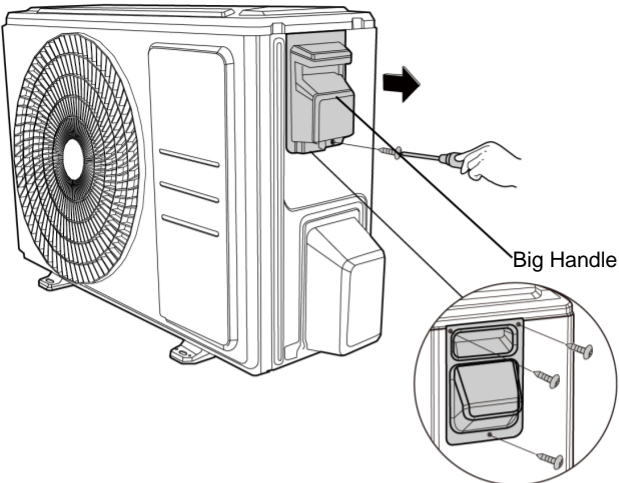
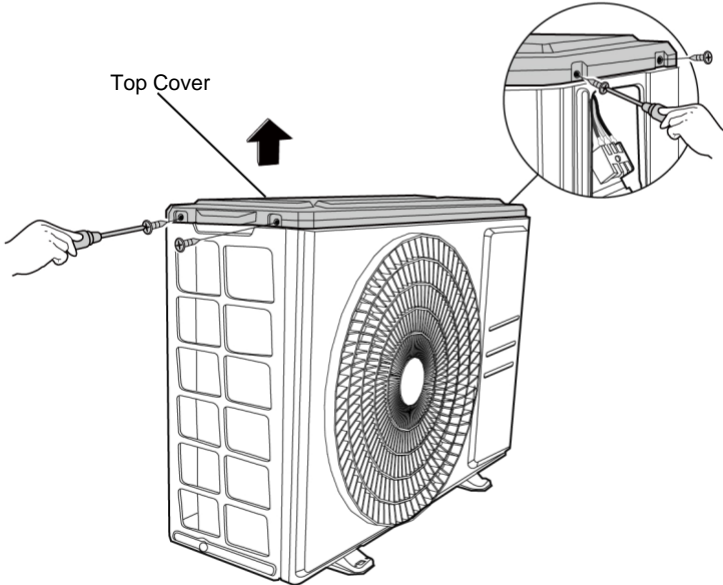
Procedure	Illustration
<p>Turn off the air conditioner and the power breaker.</p> <p>Remove the screw of the big handle and then remove the big handle (1 screws) (see CJ_X230_001).</p>	 <p>Big Handle</p> <p>CJ_X230_001</p>
<p>Remove the screws of the top cover and then remove the top cover (4 screws). One of the screws is located underneath the big handle (see CJ_X230_002).</p>	 <p>Top Cover</p> <p>CJ_X230_002</p>

**Note:** This section is for reference only. Actual unit appearance may vary.

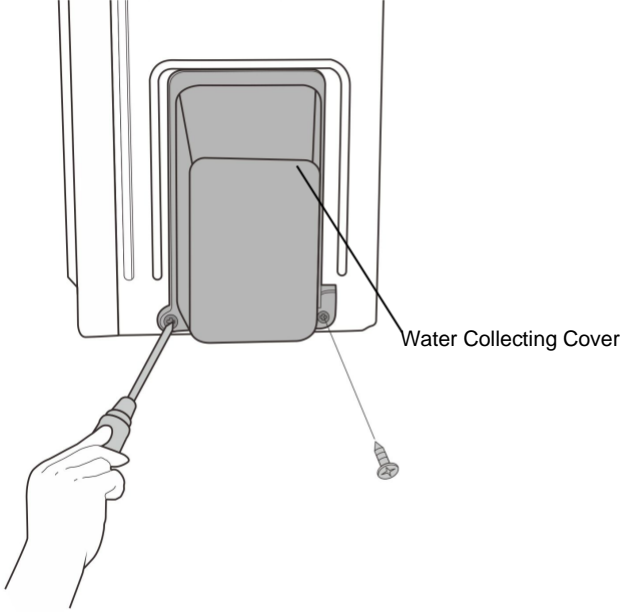
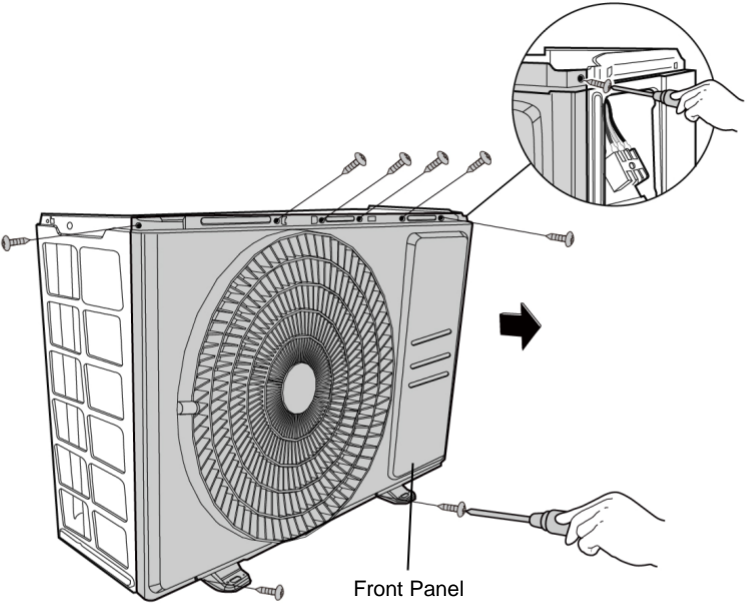
Procedure	Illustration
<p>Remove the screws of water collecting cover and then remove the water collecting cover (2 screws) (see CJ_X230_003).</p>	 <p style="text-align: center;"><b>CJ_X230_003</b></p>
<p>Remove the screws of the front panel and then remove the front panel (7 screws(onoff models) or 9 screws(inverter models) (see CJ_X230_004).</p>	 <p style="text-align: center;"><b>CJ_X230_004</b></p>

**Note:** This section is for reference only. Actual unit appearance may vary.

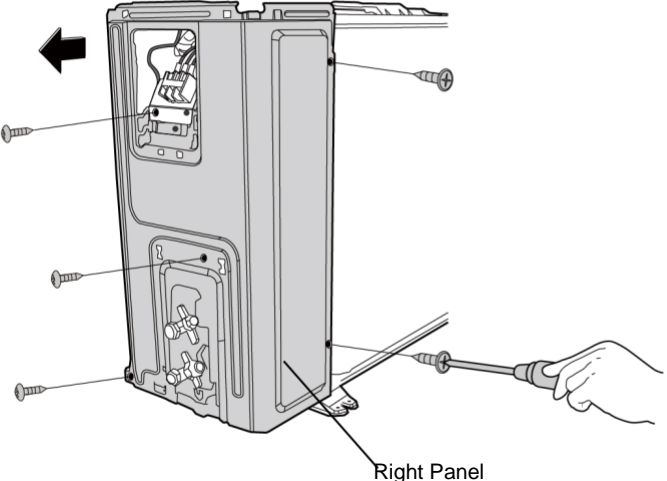
Procedure	Illustration
<p>Remove the screws of the right panel and then remove the right panel (5 screws) (see CJ_X230_005).</p>	 <p data-bbox="1070 869 1185 898">Right Panel</p> <p data-bbox="932 931 1114 965"><b>CJ_X230_005</b></p>

**Note:** This section is for reference only. Actual unit appearance may vary.

### 3. X430

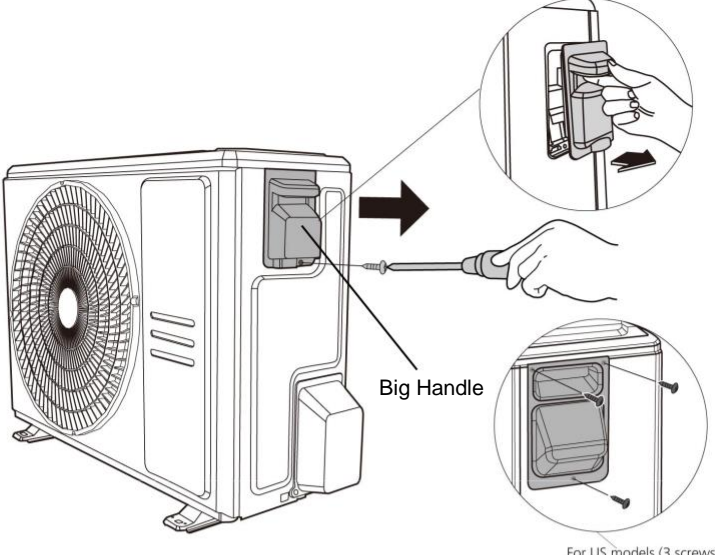
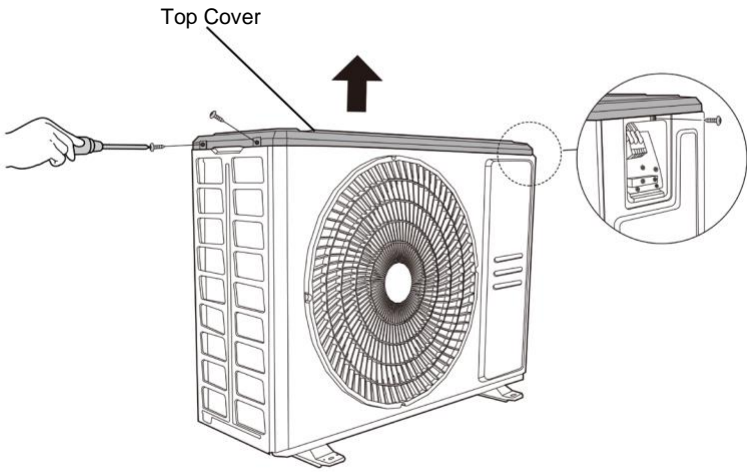
Procedure	Illustration
<p>Turn off the air conditioner and the power breaker.</p> <p>Remove the screw of the big handle and then remove the big handle (1 screw) (see CJ_X430_001).</p>	 <p>For US models (3 screws)</p> <p><b>CJ_X430_001</b></p>
<p>Remove the screws of the top cover and then remove the top cover (3 screws). One of the screws is located underneath the big handle (see CJ_X430_002).</p>	 <p><b>CJ_X430_002</b></p>

**Note:** This section is for reference only. Actual unit appearance may vary.

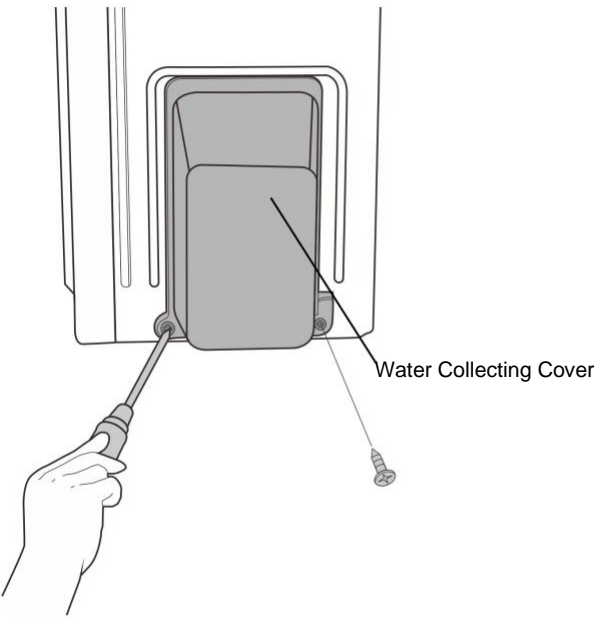
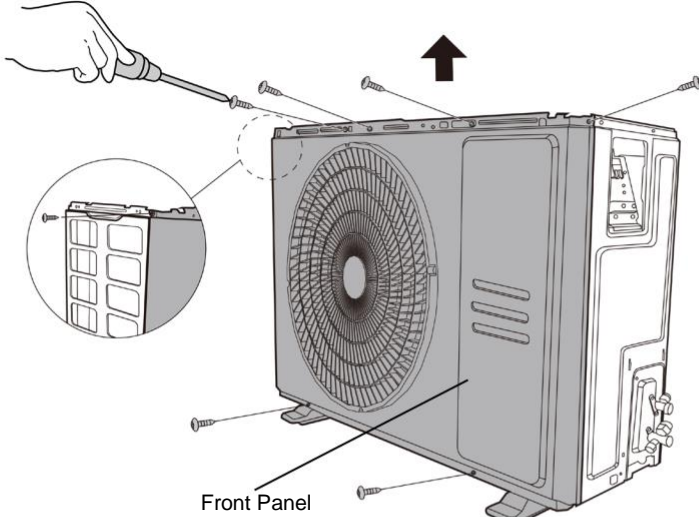

Procedure	Illustration
<p>Remove the screws of water collecting cover and then remove the water collecting cover (2 screws) (see CJ_X430_003).</p>	 <p style="text-align: center;"><b>CJ_X430_003</b></p>
<p>Remove the screws of the front panel and then remove the front panel (7 screws(onoff models) or 9 screws(inverter models) (see CJ_X430_004).</p>	 <p style="text-align: center;"><b>CJ_X430_004</b></p>

**Note:** This section is for reference only. Actual unit appearance may vary.

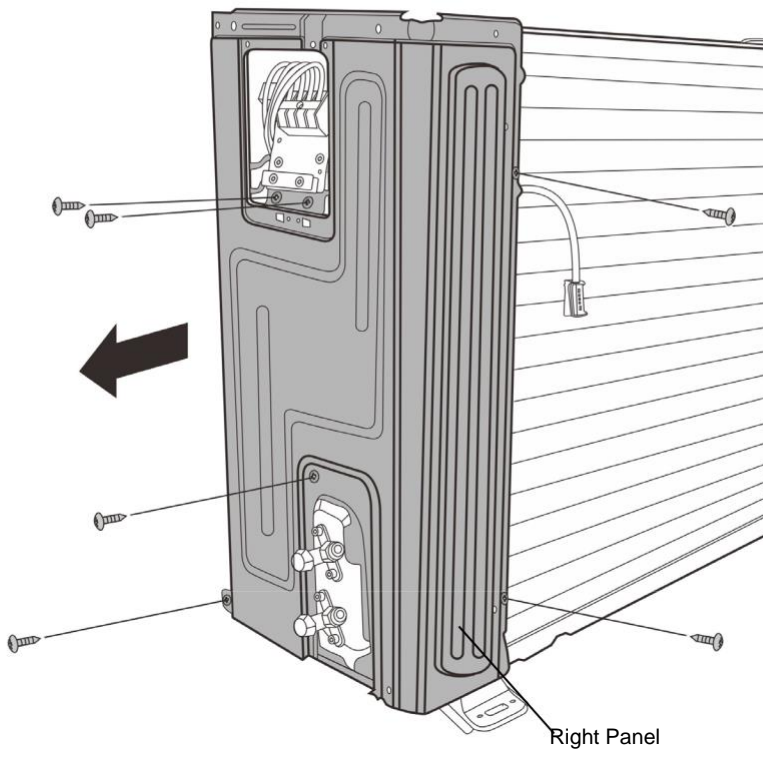
Procedure	Illustration
<p>Remove the screws of the right panel and then remove the right panel (6 screws) (see CJ_X430_005).</p>	 <p data-bbox="1181 1075 1300 1108">Right Panel</p> <p data-bbox="925 1153 1117 1198">CJ_X430_005</p>

**Note:** This section is for reference only. Actual unit appearance may vary.

## 3.2 Electrical parts

**!** **WARNING:** Antistatic gloves must be worn when you disassemble the electronic box.

**Note:** Remove the air outlet grille(refer to 3.1 Panel Plate) before disassembling electrical parts.

### PCB for Inverter Models

#### 1. PCB board 6

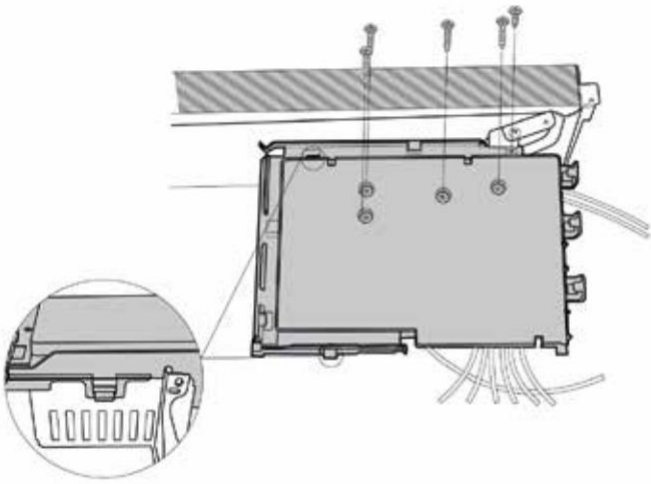
Procedure	Illustration
<p>Remove the screws and unfix the hooks, then open the electronic control box cover (5 screws and 2 hooks )(see CJ_ODU_PCB_006-1).</p>	 <p data-bbox="877 1120 1165 1153">CJ_ODU_PCB_006-1</p>

**Note:** This section is for reference only. Actual unit appearance may vary.

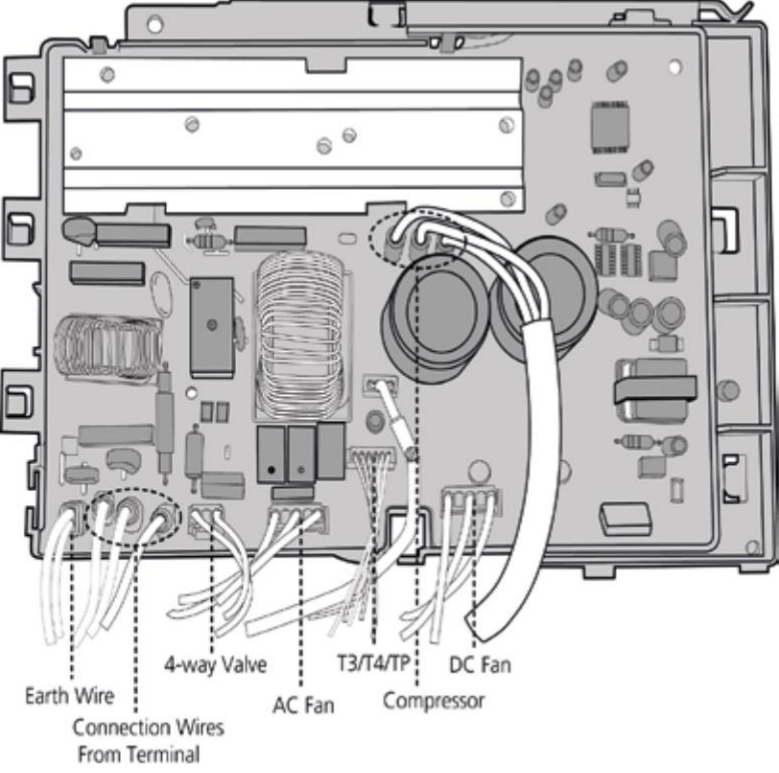
Procedure	Illustration
<p>Disconnect the connector for fan motor from the electronic control board (see CJ_ODU_PCB_006-2).</p> <p>Remove the connector for the compressor (see CJ_ODU_PCB_006-2).</p> <p>Pull out the two blue wires connected with the four way valve (see CJ_ODU_PCB_006-2).</p> <p>Pull out connectors of the condenser coil temp. sensor(T3),outdoor ambient temp. sensor(T4) and discharge temp. sensor(TP) (see CJ_ODU_PCB_006-2).</p> <p>Disconnect the electronic expansion valve wire (see Fig CJ_ODU_PCB_006-2).</p> <p>Remove the connector for the DR and reactor (see Fig CJ_ODU_PCB_006-2).</p> <p>Then remove the electronic control board.</p>	 <p style="text-align: center;"><b>CJ_ODU_PCB_006-2</b></p>

**Note:** This section is for reference only. Actual unit appearance may vary.

## 2. PCB board 9

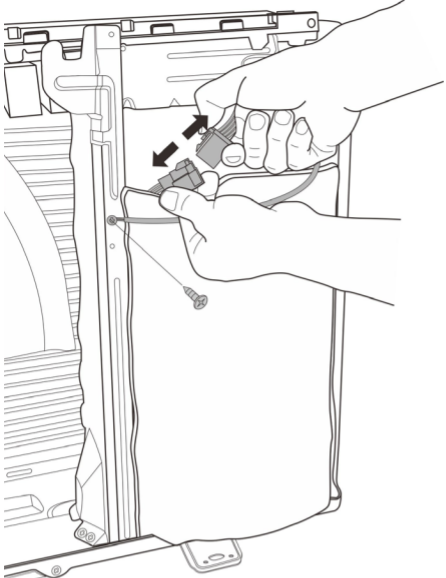
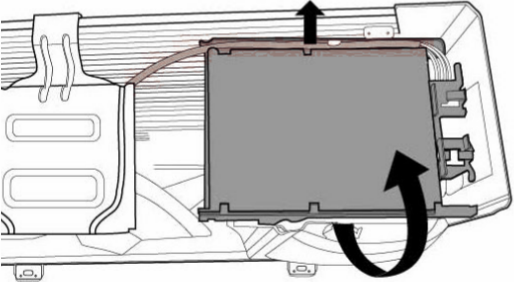
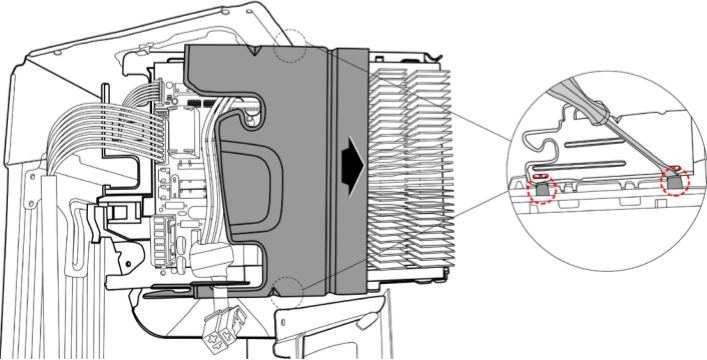
Procedure	Illustration
<p>Disconnect the connector for compressor and release the ground wire(1 screw). (see CJ_ODU_PCB_009-1).</p>	
<p>Pull out the wires from electrical supporting plate and turn over the electronic control assembly. (see CJ_ODU_PCB_009-2).</p>	
<p>Remove the electronic installing box subassembly (4 hooks) (see CJ_ODU_PCB_009-3).</p>	

**Note:** This section is for reference only. Actual unit appearance may vary.

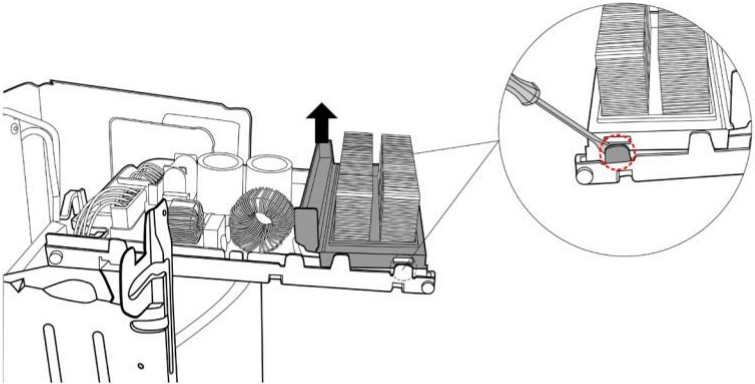
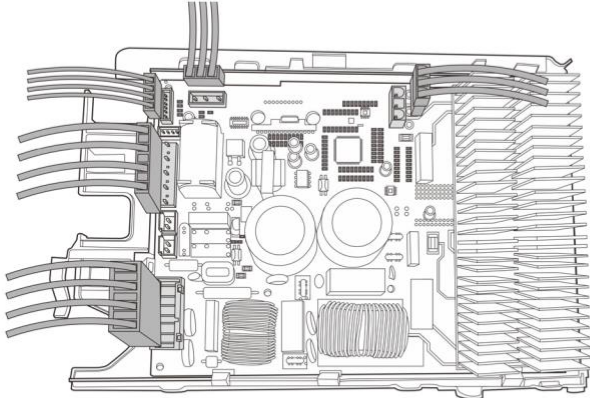
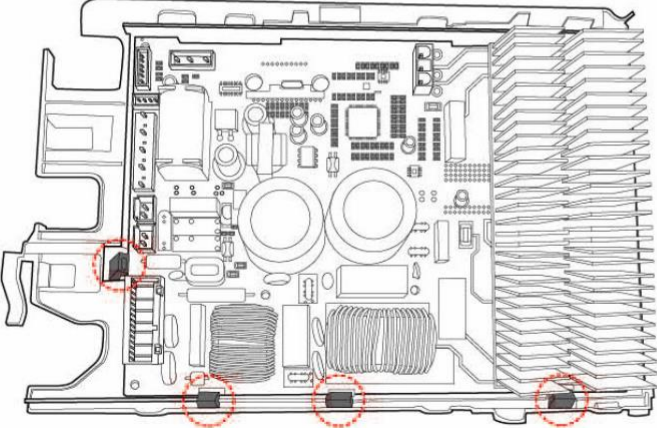
Procedure	Illustration
<p>Remove the fixing board (2 hooks) (see CJ_ODU_PCB_009-4).</p>	 <p style="text-align: center;"><b>CJ_ODU_PCB_009-4</b></p>
<p>Disconnect the connectors from the electronic control board (see CJ_ODU_PCB_009-5).</p>	 <p style="text-align: center;"><b>CJ_ODU_PCB_009-5</b></p>
<p>Then remove the electronic control board (4 hooks).(see CJ_ODU_PCB_009-6).</p>	 <p style="text-align: center;"><b>CJ_ODU_PCB_009-6</b></p>

**Note:** This section is for reference only. Actual unit appearance may vary.

### 3.3 Fan Assembly

**Note:** Remove the panel plate (refer to 3.1 Panel Plate) before disassembling fan.

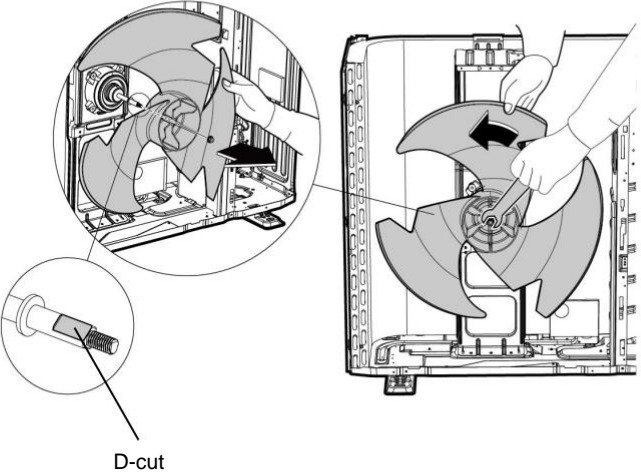
Procedure	Illustration
<p>Remove the nut securing the fan with a spanner (see CJ_ODU_FAN_001).</p> <p>Remove the fan.</p>	 <p data-bbox="874 1003 1123 1032">CJ_ODU_FAN_001</p>

**Note:** This section is for reference only. Actual unit appearance may vary.

### 3.4 Fan Motor

**Note:** Remove the panel plate and the connection of fan motor on PCB (refer to 3.1 Panel Plate and 3.2 Electrical parts) before disassembling fan motor.

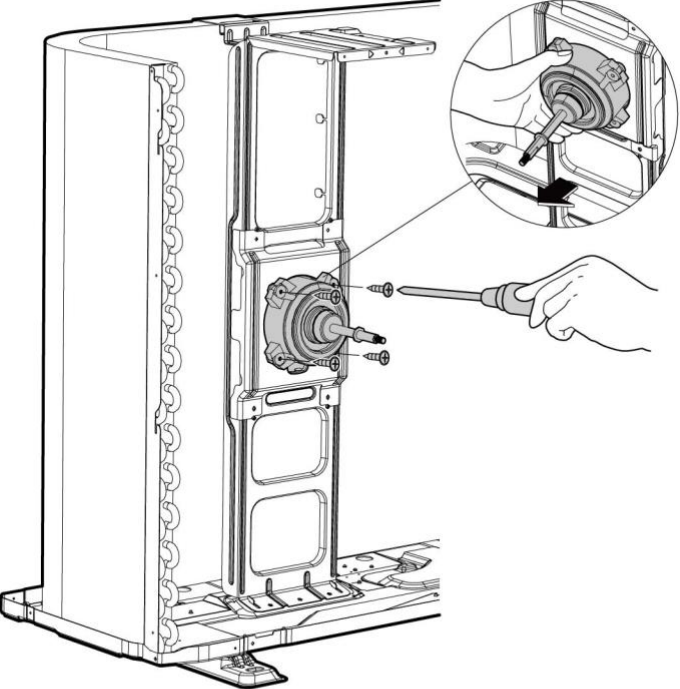
Procedure	Illustration
<p>Remove the fixing screws of the fan motor (4 screws) (see CJ_ODU_MOTOR_001).</p> <p>Remove the fan motor.</p>	 <p data-bbox="884 1238 1182 1272">CJ_ODU_MOTOR_001</p>

**Note:** This section is for reference only. Actual unit appearance may vary.



### 3.5 Sound blanket

Note: Remove the panel plate (refer to 3.1 Panel plate) before disassembling sound blanket.

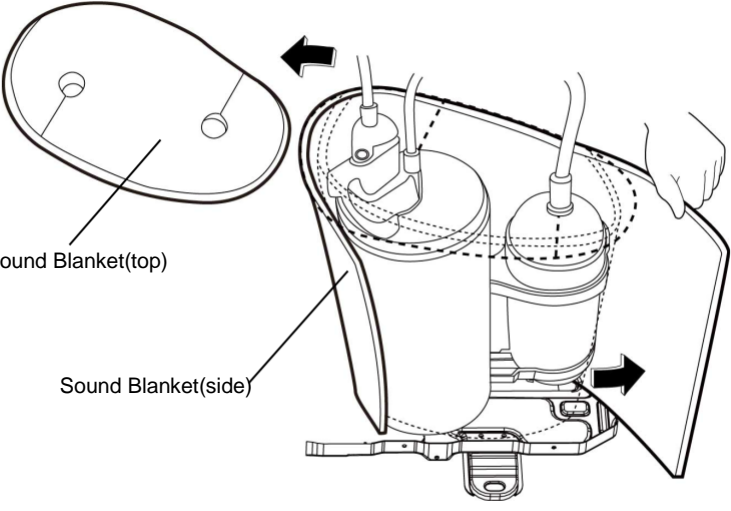
Procedure	Illustration
<p>Remove the sound blanket (side and top) (see CJ_ODU_BLANKET_001).</p>	 <p>CJ_ODU_BLANKET_001</p>

Note: This section is for reference only. Actual unit appearance may vary.

### 3.6 Four-way valve (for heat pump models)

**! WARNING:** Evacuate the system and confirm that there is no refrigerant left in the system before removing the four-way valve and the compressor. (For R32 & R290, you should evacuate the system with the vacuum pump; flush the system with nitrogen; then repeat the two steps before heating up the brazed parts. The operations above should be implemented by professionals.)

**Note:** Remove the panel plate, connection of four-way valve on PCB (refer to 3.1 Panel plate and 3.2 Electrical parts) before disassembling sound blanket.

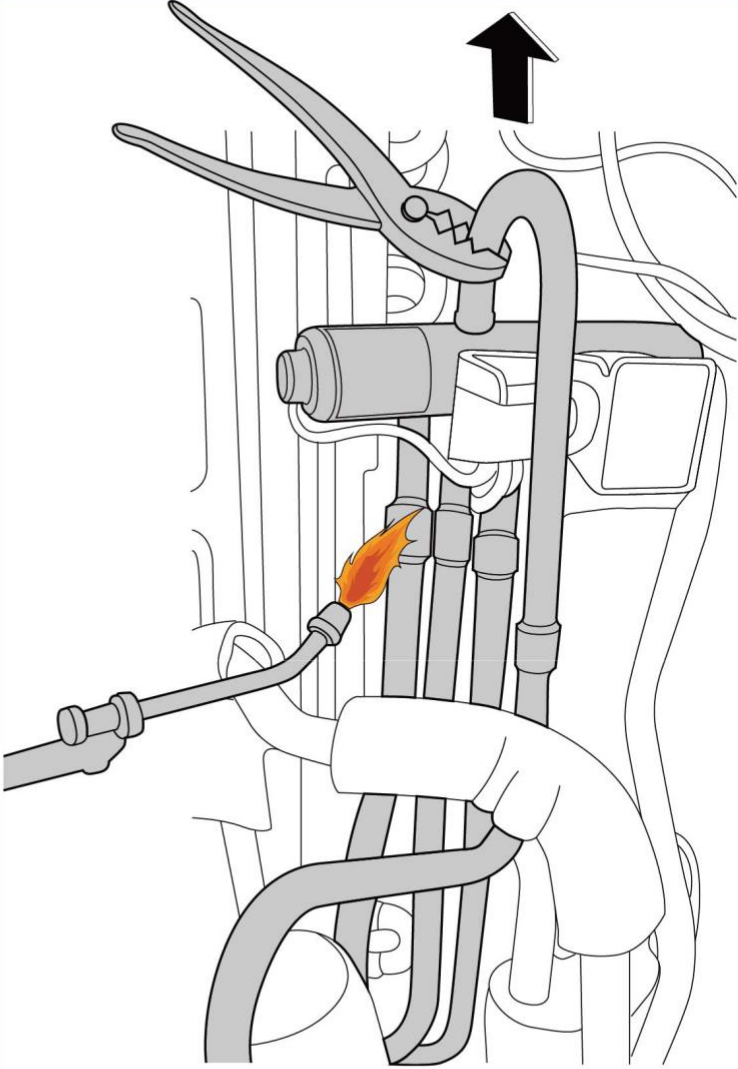
Procedure	Illustration
<p>Heat up the brazed parts and then detach the the four-way valve and the pipe (see CJ_ODU_VALVE_001).</p> <p>Remove the four-way valve assembly with pliers.</p>	 <p>CJ_ODU_VALVE_001</p>

**Note:** This section is for reference only. Actual unit appearance may vary.

### 3.7 Compressor

**! WARNING:** Evacuate the system and confirm that there is no refrigerant left in the system before removing the four-way valve and the compressor. (For R32 & R290, you should evacuate the system with the vacuum pump; flush the system with nitrogen; then repeat the two steps before heating up the brazed parts. The operations above should be implemented by professionals.)

**Note:** Remove the panel plate, connection of compressor on PCB (refer to 3.1 Panel plate and 3.2 Electrical parts) before disassembling sound blanket.

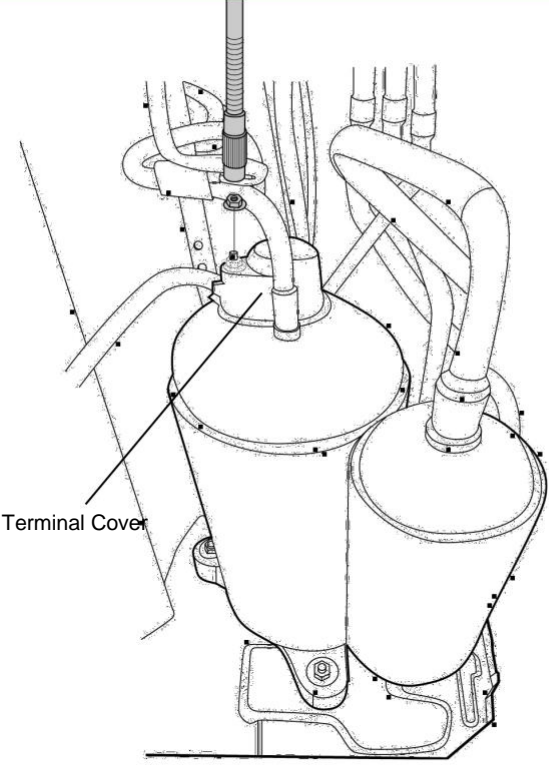
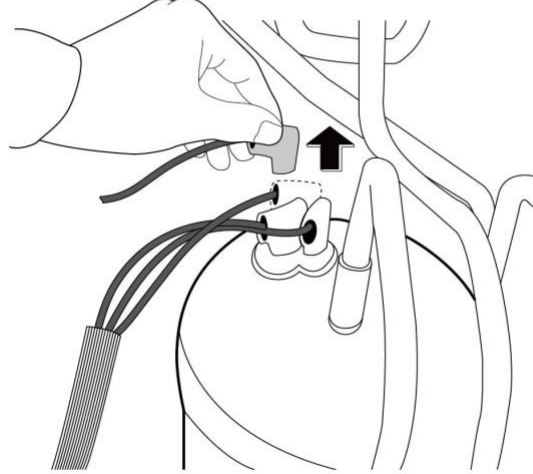
Procedure	Illustration
<p>Remove the flange nut of terminal cover and remove the terminal cover (see CJ_ODU_COMP_001).</p>	 <p>Terminal Cover</p> <p>CJ_ODU_COMP_001</p>
<p>Disconnect the connectors (see CJ_ODU_COMP_002).</p>	 <p>CJ_ODU_COMP_002</p>

**Note:** This section is for reference only. Actual unit appearance may vary.

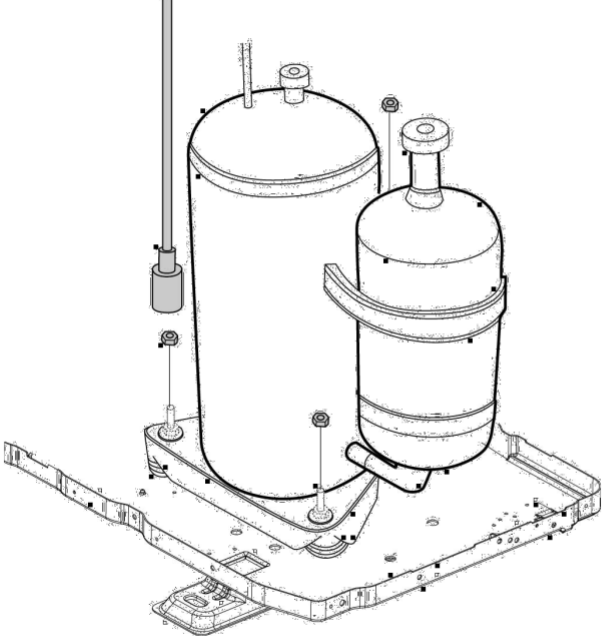
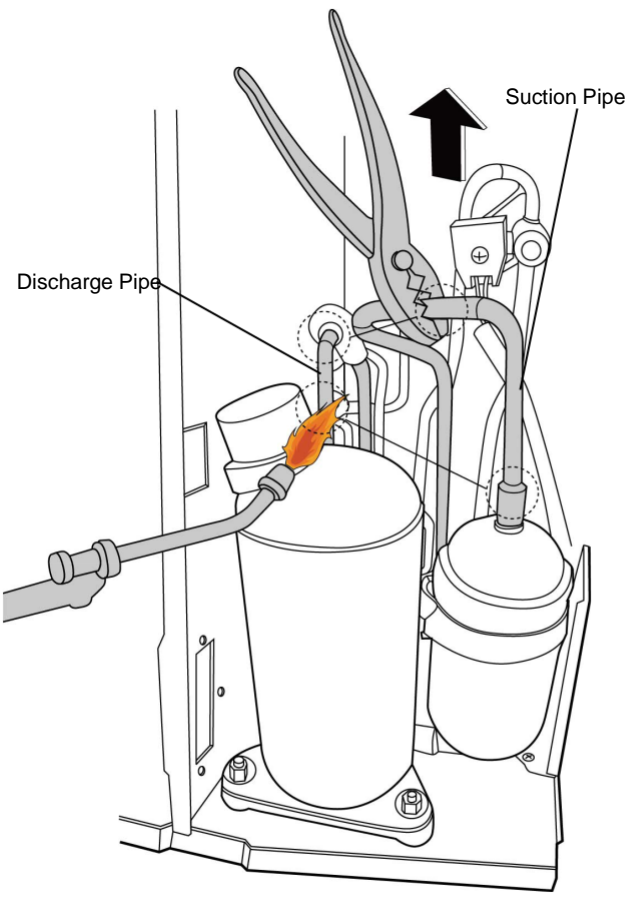
Procedure	Illustration
<p>Remove the hex nuts and washers securing the compressor, located on the bottom plate (see CJ_ODU_COMP_003).</p>	 <p style="text-align: center;"><b>CJ_ODU_COMP_003</b></p>
<p>Heat up the brazed parts and then remove the the discharge pipe and the suction pipe (see CJ_ODU_COMP_004).</p> <p>Lift the compressor from the base pan assembly with pliers.</p>	 <p style="text-align: center;"><b>CJ_ODU_COMP_004</b></p>

**Note:** This section is for reference only. Actual unit appearance may vary.

---

# Troubleshooting

## Contents

<b>1. Safety Caution</b> .....	<b>3</b>
<b>2. General Troubleshooting</b> .....	<b>4</b>
<b>3. Complain Record Form</b> .....	<b>7</b>
<b>4. Information Inquiry</b> .....	<b>9</b>
<b>5. Error Diagnosis and Troubleshooting Without Error Code</b> .....	<b>12</b>
5.1 Remote maintenance.....	12
5.2 Field maintenance.....	13
<b>6. Quick Maintenance by Error Code</b> .....	<b>18</b>
<b>7. Troubleshooting by Error Code</b> .....	<b>19</b>
7.1 E0/EH 00 / F4/EC 51 (EEPROM parameter error diagnosis and solution).....	19
7.2 E1/EL 01 (Indoor and outdoor unit communication error diagnosis and solution). 20	20
7.3 E2/EH 02 (Zero-crossing detection error diagnosis and solution).....	22
7.4 E3/EH 03 / F5/EC 07 (Fan speed is operating outside of the normal range diagnosis and solution).....	23
7.5 E4/EH 60/E5/EH 61/F1/EC 53/F2/EC 52/F3/EC 54/F6/EC 56 (Open circuit or short circuit of temperature sensor diagnosis and solution).....	26
7.6 E7/EH 0b (Indoor PCB / Display board communication error diagnosis and solution).....	27
7.7 EC/EL 0C (Refrigerant Leakage Detection diagnosis and solution).....	28

---

# Troubleshooting

## Contents

7.8	F0/PC 08 (Overload current protection diagnosis and solution).....	29
7.9	P0/PC 00 (IPM malfunction or IGBT over-strong current protection diagnosis and solution).....	30
7.10	P1/PC 01 (Over voltage or too low voltage protection diagnosis and solution).....	31
7.11	P2/PC 02 (High temperature protection of IPM module or High pressure protection diagnosis and solution).....	32
7.12	P4/PC 04 (Inverter compressor drive error diagnosis and solution).....	34
7.13	P6/PC 03 (Low pressure protection diagnosis and solution).....	35
<b>8.</b>	<b>Check Procedures.....</b>	<b>37</b>

## 1. Safety Caution

### WARNING

Be sure to turn off all power supplies or disconnect all wires to avoid electric shock. While checking indoor/outdoor PCB, please equip oneself with antistatic gloves or wrist strap to avoid damage to the board.

### WARNING

Electricity remains in capacitors even when the power supply is off. Ensure the capacitors are fully discharged before troubleshooting.

Test the voltage between P and N on back of the main PCB with multimeter. If the voltage is lower than 36V, the capacitors are fully discharged.

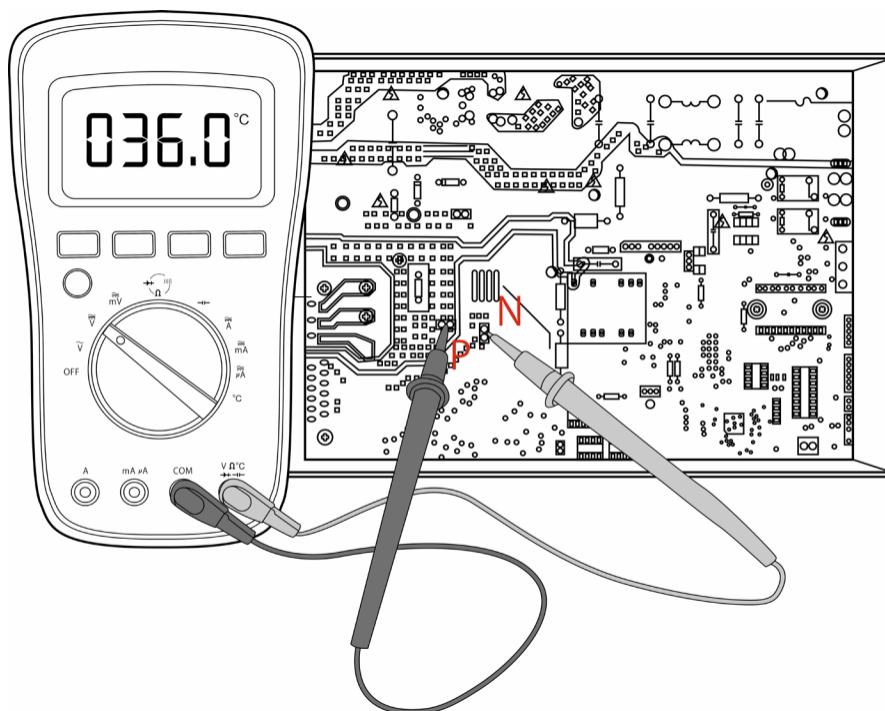

**Note:** This picture is for reference only. Actual appearance may vary.

## 2. General Troubleshooting

### 2.1 Error Display (Indoor Unit)

When the indoor unit encounters a recognized error, the operation lamp will flash in a corresponding series, the timer lamp may turn on or begin flashing, and an error code will be displayed. These error codes are described in the following tables:

Operation Lamp	Timer Lamp	Display	Error Information	Solution
1 time	OFF	E0	Indoor unit EEPROM parameter error	TS19
2 times	OFF	E1	Indoor / outdoor unit communication error	TS20
3 times	OFF	E2	Zero-crossing signal detection error(for some models)	TS22
4 times	OFF	E3	The indoor fan speed is operating outside of the normal range	TS23
5 times	OFF	E4	Indoor room temperature sensor T1 is in open circuit or has short circuited	TS26
6 times	OFF	E5	Evaporator coil temperature sensor T2 is in open circuit or has short circuited	TS26
9 times	OFF	E7/EH	Indoor PCB / Display board communication error(for some models)	TS27
7 times	OFF	EC	Refrigerant leak detected	TS28
1 times	ON	F0	Current overload protection	TS29
2 times	ON	F1	Outdoor room temperature sensor T4 is in open circuit or has short circuited	TS26
3 times	ON	F2	Condenser coil temperature sensor T3 is in open circuit or has short circuited	TS26
4 times	ON	F3	Compressor discharge temperature sensor TP is in open circuit or has short circuited	TS26
7 times	ON	F6	Evaporator coil outlet temperature sensor T2B is in open circuit or has short circuited(for free-match indoor units)	TS26
5 times	ON	F4	Outdoor unit EEPROM parameter error	TS19
6 times	ON	F5	The outdoor fan speed is operating outside of the normal range(for some models)	TS23
1 times	FLASH	P0	IPM malfunction or IGBT over-strong current protection	TS30
2 times	FLASH	P1	Over voltage or over low voltage protection	TS31
3 times	FLASH	P2	High temperature protection of IPM module or High pressure protection	TS32
5 times	FLASH	P4	Inverter compressor drive error	TS34
7 times	FLASH	P6	Low pressure protection(for some models)	TS35
6 times	FLASH	P5/--	Indoor units mode conflict(match with multi outdoor unit)	--

#### For other errors:

The display board may show a garbled code or a code undefined by the service manual. Ensure that this code is not a temperature reading.

#### Troubleshooting:

Test the unit using the remote control. If the unit does not respond to the remote, the indoor PCB requires replacement. If the unit responds, the display board requires replacement.



**For some models**

Operation Lamp	Timer Lamp	LED Display	Error Information	Solution
1 time	OFF	EH 00	Indoor unit EEPROM parameter error	TS19
2 times	OFF	EL 01	Indoor / outdoor unit communication error	TS20
3 times	OFF	EH 02	Zero-crossing signal detection error(for some models)	TS22
4 times	OFF	EH 03	The indoor fan speed is operating outside of the normal range	TS23
5 times	OFF	EC 51	Outdoor unit EEPROM parameter error(for some models)	TS19
5 times	OFF	EC 52	Condenser coil temperature sensor T3 is in open circuit or has short circuited	TS26
5 times	OFF	EC 53	Outdoor room temperature sensor T4 is in open circuit or has short circuited	TS26
5 times	OFF	EC 54	Compressor discharge temperature sensor TP is in open circuit or has short circuited	TS26
5 times	OFF	EC 56	Evaporator coil outlet temperature sensor T2B is in open circuit or has short circuited(for free-match indoor units)	TS26
6 times	OFF	EH 60	Indoor room temperature sensor T1 is in open circuit or has short circuited	TS26
6 times	OFF	EH 61	Evaporator coil temperature sensor T2 is in open circuit or has short circuited	TS26
12 times	OFF	EC 07	The outdoor fan speed is operating outside of the normal range(for some models)	TS23
9 times	OFF	EH 62	Indoor PCB / Display board communication error(for some models)	TS27
8 times	OFF	EL 0C	Refrigerant leak detected	TS28
7 times	FLASH	PC 00	IPM malfunction or IGBT over-strong current protection	TS30
2 times	FLASH	PC 01	Over voltage or over low voltage protection	TS31
3 times	FLASH	PC 02	High temperature protection of IPM module or High pressure protection	TS32
5 times	FLASH	PC 04	Inverter compressor drive error	TS34
1 time	FLASH	PC 08	Current overload protection(for some models)	TS29
7 times	FLASH	PC 03	Low pressure protection(for some models)	TS35
1 times	ON	--	Indoor units mode conflict(match with multi outdoor unit)	--

---

### LED flash frequency:

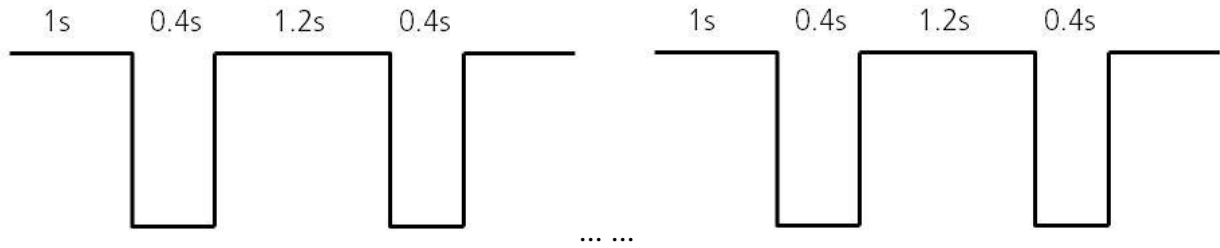

## 2.2 Error Display (For Some Outdoor Units)

There are 2 LED lights (RED color and GREEN color) welded in outdoor main board. After power on, LED show different actions when encounter different problems.

No.	Problem	LED(GREEN)	LED(RED)	Solution
1	Standby normally	ON	OFF	-
2	Operate normally	OFF	ON	-
3	Compressor driven chip EEPROM parameter error	ON	FLASH	TS19
4	IPM malfunction or IGBT over-strong current protection	FLASH	OFF	TS30
5	Over voltage or too low voltage protection	ON	ON	TS31
6	Inverter compressor drive error	OFF	FLASH	TS34
7	Inverter compressor drive error	FLASH	LIGHT	TS34
8	Communication error between outdoor main chip and compressor driven chip	FLASH	FLASH	TS19

### 3. Complain Record Form

#### Complain Record Form

Request No.:

Date:

Installation Date:

Service Date:

Customer Information			
Name		Telephone No.	
Home Address			
Email			
Product Information			
Indoor Unit Model		Outdoor Unit Model	
Serial No. of indoor unit			
Serial No. of outdoor unit			
Working Mode	<input type="checkbox"/> Cooling <input type="checkbox"/> Heating <input type="checkbox"/> Fan only <input type="checkbox"/> Dry		
Setting temperature	_____ °C/°F	Fan speed	<input type="checkbox"/> Turbo <input type="checkbox"/> High <input type="checkbox"/> Medium <input type="checkbox"/> Low <input type="checkbox"/> Auto
Temperature of air inlet	_____ °C/°F	Temperature of air outlet	_____ °C/°F
Installation / Condition Information			
Indoor temperature	_____ °C/°F	Indoor humidity	_____ %RH
Outdoor temperature	_____ °C/°F	Outdoor humidity	_____ %RH
Length of Connecting pipe		Pipe diameter	Gas pipe: _____ Liquid pipe: _____
Length of Wiring		wire diameter	
System Running Pressure	_____ MPa or _____ Bar or _____ PSI		
Room size (L*W*H)			
Photo of Installation of Indoor unit (Photo #1)		Photo of Installation of Outdoor unit (Photo #2)	
Failure Description			
Error Code of Indoor unit		Code of Outdoor PCB	
Unit does not start			
Remote control does not work			
Indoor display shows nothing			
No cooling or heating at all			
Less cooling or heating			
Unit starts but stops shortly			
High noise			
High vibration			

Parameter Checking information by Remote controller			
Displaying code	Displaying code meaning	Display value	Display value meaning
T1	Room temperature		
T2	Indoor coil temperature		
T3	Outdoor coil temperature		
T4	Ambient temperature		
Tb	Outlet temperature of indoor coil		
TP	Discharge temperature		
TH	Suction temperature		
FT	Targeted Frequency		
Fr	Actual Frequency		
IF	Indoor fan speed		
OF	Outdoor fan speed		
LA	EXV opening steps		
CT	Compressor continuous running time		
ST	Causes of compressor stop.		
A0, A1, b0, b1, b2, b3, b4, b5, b6, dL, Ac, Uo, Td, dA, dS, dT	Reserved		

Approval from Manufacturer	
<input type="checkbox"/> Approved	
<input type="checkbox"/> More Proof needed	
<input type="checkbox"/> Rejected	

---

## Information Inquiry

To enter information inquiry status, complete the following procedure within ten seconds:

Press LED(or DO NOT DISTURB) 3 times.

Press SWING(or AIR DIRECTION) 3 times.

Finish 1 and 2 within 10 seconds, you will hear beeps for two seconds, which means the unit goes into parameter checking mode.

Use the LED(or DO NOT DISTURB) and SWING(or AIR DIRECTION) buttons to cycle through information displayed.

Pressing LED(or DO NOT DISTURB) will display the next code in the sequence. Pressing SWING(or AIR DIRECTION) will show the previous.

The following table shows information codes. The screen will display this code for two seconds, then the information for 25 seconds.

Displayed code	Explanation	Displayed value	Meaning	Additional Notes
T1	Room temperature	-1F,-1E,-1d,-1c,-1b,-1A	-25,-24,-23,-22,-21,-20	<ol style="list-style-type: none"> <li>All displayed temperatures use actual values.</li> <li>All temperatures are displayed in °C regardless of remote used.</li> <li>T1, T2, T3, T4, and T2B display ranges from -25 to 70 °C. TP display ranges from -20 to 130 °C.</li> <li>The frequency display ranges from 0 to 159HZ.</li> <li>If the actual values exceed or fall short of the defined range, the values closest to the maximum and minimum values will be displayed.</li> </ol>
T2	Indoor coil temperature			
T3	Outdoor coil temperature			
T4	Ambient temperature	-19—99	-19—99	
TB	Outlet temperature of indoor coil	A0,A1,...A9	100,101,...109	
TP	Discharge temperature	b0,b1,...b9	110,111,...119	
TH	Suction temperature	c0,c1,...c9	120,121,...129	
FT	Targeted frequency	d0,d1,...d9	130,131,...139	
FR	Actual frequency	E0,E1,...E9	140,141,...149	
IF	Indoor fan speed	F0,F1,...F9	150,151,...159	
		0	OFF	N/A
		1,2,3,4	Low speed, Medium speed, High speed, Turbo.	Used for some large capacity motors.
OF	Outdoor fan speed	14-FF	Actual fan speed is equal to the display value converted to decimal value and multiplied by 10. This is measured in RPM.	Used for some small capacity motors. The display value is 14-FF (hexadecimal). The corresponding fan speed ranges from 200 to 2550RPM.
LA	EXV opening angle	0-FF	Actual EXV opening value is equal to the display value converted to decimal value and then multiplied by 2.	-
CT	Compressor continuous running time	0-FF	0-255 minutes	If the actual value exceeds or falls short of the defined range, the value closest to the maximum and minimum will be displayed.
ST	Causes of compressor stop	0-99	For a detailed explanation, contact technical support.	-

Displayed code	Explanation	Displayed value	Meaning	Additional Notes
A0	Reserved	0-FF 2-28 5-20 5-25	-	-
A1				
b <sub>0</sub>				
b <sub>1</sub>				
b <sub>2</sub>				
b <sub>3</sub>				
b <sub>4</sub>				
b <sub>5</sub>				
b <sub>6</sub>				
d <sub>L</sub>				
AC				
U <sub>0</sub>				
T <sub>d</sub>				
d <sub>A</sub>				
d <sub>S</sub>				
d <sub>T</sub>				

---

## 5. Error Diagnosis and Troubleshooting Without Error Code



### WARNING

Be sure to turn off unit before any maintenance to prevent damage or injury.

### 5.1 Remote maintenance

**SUGGESTION:** When troubles occur, please check the following points with customers before field maintenance.

No.	Problem	Solution
1	Unit will not start	TS14 - TS15
2	The power switch is on but fans will not start	TS14 - TS15
3	The temperature on the display board cannot be set	TS14 - TS15
4	Unit is on but the wind is not cold(hot)	TS14 - TS15
5	Unit runs, but shortly stops	TS14 - TS15
6	The unit starts up and stops frequently	TS14 - TS15
7	Unit runs continuously but insufficient cooling(heating)	TS14 - TS15
8	Cool can not change to heat	TS14 - TS15
9	Unit is noisy	TS14 - TS15



---

## 5.2 Field maintenance

	Problem	Solution
1	Unit will not start	TS16 - TS17
2	Compressor will not start but fans run	TS16 - TS17
3	Compressor and condenser (outdoor) fan will not start	TS16 - TS17
4	Evaporator (indoor) fan will not start	TS16 - TS17
5	Condenser (Outdoor) fan will not start	TS16 - TS17
6	Unit runs, but shortly stops	TS16 - TS17
7	Compressor short-cycles due to overload	TS16 - TS17
8	High discharge pressure	TS16 - TS17
9	Low discharge pressure	TS16 - TS17
10	High suction pressure	TS16 - TS17
11	Low suction pressure	TS16 - TS17
12	Unit runs continuously but insufficient cooling	TS16 - TS17
13	Too cool	TS16 - TS17
14	Compressor is noisy	TS16 - TS17
15	Horizontal louver can not revolve	TS16 - TS17

Possible causes of trouble	Electrical Circuit	Refrigerant Circuit
Unit will not start	☆☆☆☆	
The power switch is on but fans will not start	☆☆☆	
The temperature on the display board cannot be set		☆☆
Unit is on but the wind is not cold(hot)		☆☆☆
Unit runs, but shortly stops	☆	☆☆☆
The unit starts up and stops frequently	☆	☆☆☆
Unit runs continuously but insufficient cooling(heating)		☆☆☆☆☆
Cool can not change to heat		☆☆☆☆☆
Unit is noisy		☆☆☆☆☆
Test method / remedy	Check power supply	
	Check power switch	
	Check fan motor	
	Check fan capacitor	
	Check fan winding	
	Check fan speed	
	Check fan voltage	
	Check fan current	
	Check fan temperature	
	Check fan noise	
Adjust the setting temperature		
Turn the AC later		

## 1.Remote Maintenance

## Others

### Possible causes of trouble

Loosen hold down bolts and / or screws  
 Bad airproof  
 The air inlet or outlet of either unit is blocked  
 Interference from cell phone towers and remote  
 boosters  
 Shipping plates remain attached

Unit will not start			
The power switch is on but fans will not start			☆
The temperature on the display board cannot be set			
Unit is on but the wind is not cold(hot)			
Unit runs, but shortly stops			
The unit starts up and stops frequently			☆
Unit runs continuously but insufficient cooling(heating)	☆	☆	☆
Cool can not change to heat			
Unit is noisy	☆		☆

### Test method / remedy

Tighten bolts or screws  
 Close all the windows and doors  
 Remove the obstacles  
 ON/OFFReconnectthepowerorpress button  
 Remove them  
 on remote control to restart operation

2.Field Maintenance	Refrigerant Circuit				Others																					
Possible causes of trouble	Compressor stuck	Shortage of refrigerant	Restricted liquid line	Dirty air filter	Dirty evaporator coil	Insufficient air through evaporator coil	Overcharge of refrigerant	Dirty or partially blocked condenser	Air or incompressible gas in refrigerant cycle	Short cycling of condensing air	High temperature condensing medium	Insufficient condensing medium	Broken compressor internal parts	Inefficient compressor	Expansion valve obstructed	Expansion valve or capillary tube closed completely	Leaking power element on expansion valve	Poor installation of feeler bulb	Heavy load condition	Loosen hold down bolts and / or screws	Shipping plates remain attached	Poor choices of capacity	Contact of piping with other piping or external plate			
Test method / remedy	Replace the compressor	Leak test	Replace restricted part	Clean or replace	Clean coil	Check fan	Change charged refrigerant volume	Clean condenser or remove obstacle	Purge, evacuate and recharge	Remove obstruction to air flow	Remove obstruction in air or water flow	Remove obstruction in air or water flow	Replace compressor	Test compressor efficiency	Replace valve	Replace valve	Replace valve	Fix feeler bulb	Check heat load	Tighten bolts or screws	Remove them	Choose AC of larger capacity or add the number of AC	Rectify piping so as not to contact each other or withplate	external		
Unit will not start																										
Compressor will not start but fans run		☆																								
Compressor and condenser (outdoor) fan will not start																										
Evaporator (indoor) fan will not start																										
Condenser (Outdoor) fan will not start																										
Unit runs, but shortly stops		☆ ☆					☆ ☆									☆ ☆										
Compressor short-cycles due to overload		☆					☆ ☆																			
High discharge pressure							☆ ☆ ☆ ☆ ☆ ☆ ☆ ☆																			
Low discharge pressure		☆											☆													
High suction pressure							☆					☆							☆ ☆							
Low suction pressure		☆ ☆ ☆ ☆ ☆ ☆													☆ ☆ ☆											
Unit runs continuously but insufficient cooling		☆ ☆ ☆ ☆ ☆ ☆					☆ ☆ ☆					☆							☆				☆			
Too cool																										
Compressor is noisy							☆					☆									☆ ☆				☆	
Horizontal louver can not revolve																										

## 2. Field Maintenance

## Electrical Circuit

### Possible causes of trouble

- Power failure
- Brown out/voltage drop
- Loose connections
- Shorted capacitor wires
- Slip phase caps
- Faulty thermostat/room temperature sensor
- High pressure sensor/pressure switch failure
- Shorted compressor
- Faulty run/condenser fan compressor
- Faulty run/condenser fan
- Low voltage
- Faulty stoppage sensor
- Shorted run/condenser fan compressor
- Shorted run/condenser fan

Unit will not start	☆☆☆☆☆	☆			
Compressor will not start but fans run	☆	☆	☆	☆	☆
Compressor and condenser (outdoor) fan will not start	☆	☆		☆	
Evaporator (indoor) fan will not start	☆		☆	☆	☆
Condenser (Outdoor) fan will not start	☆	☆	☆	☆	☆
Unit runs, but shortly stops				☆	☆
Compressor short-cycles due to overload				☆	☆
High discharge pressure					
Low discharge pressure					
High suction pressure					
Low suction pressure					
Unit runs continuously but insufficient cooling					
Too cool		☆☆			
Compressor is noisy					
Horizontal louver can not revolve	☆☆				☆

### Test method / remedy

- Test voltage
- Inspect fan/panda
- Inspect connections/switch
- Inspect capacitor
- Test room quality sensor
- Test room air pressure/room air sensor during
- air inlet
- Check capacitor with ohm
- Test room air quality sensor
- Inspect fan/panda
- Test voltage
- Inspect fan/panda
- Check air intake/louver
- Check air intake/louver

## 6. Quick Maintenance by Error Code

If you do not have the time to test which specific parts are faulty, you can directly change the required parts according to the error code.

You can find the parts to replace by error code in the following table.

Part requiring replacement	Error Code								
	E0	E1	E2	E3	E4	E5	E7/Eb	EC	F0
	EH 00	EEL 01	EH 02	EH 03	EH 60	EH 61	EH 0b	EL 0C	PC 08
Indoor PCB	✓	✓	✓	✓	✓	✓	✓	✓	✗
Outdoor PCB	✗	✓	✗	✗	✗	✗	✗	✗	✓
Display board	✗	✗	✗	✗	✗	✗	✓	✗	✗
Indoor fan motor	✗	✗	✗	✓	✗	✗	✗	✗	✗
T1 sensor	✗	✗	✗	✗	✓	✗	✗	✗	✗
T2 Sensor	✗	✗	✗	✗	✗	✓	✗	✓	✗
Reactor	✗	✓	✗	✗	✗	✗	✗	✗	✗
Compressor	✗	✗	✗	✗	✗	✗	✗	✗	✓
Additional refrigerant	✗	✗	✗	✗	✗	✗	✗	✓	✗

Part requiring replacement	F1	F2	F3	F6	F4	F5	P0	P1	P2	P6	P4
	EC 53	EC 52	EC 54	EC 56	EC 51	EC 07	PC 00	PC 01	PC 02	PC 03	PC 04
Indoor PCB	✗	✗	✗	✗	✗	✗	✗	✗	✗	✗	✗
Outdoor PCB	✓	✓	✓	✓	✓	✓	✓	✓	✓	✓	✓
Indoor fan motor	✗	✗	✗	✗	✗	✗	✗	✗	✗	✗	✗
Outdoor fan motor	✗	✗	✗	✗	✗	✓	✓	✗	✓	✗	✓
T3 Sensor	✗	✓	✗	✗	✗	✗	✗	✗	✗	✗	✗
T4 Sensor	✓	✗	✗	✗	✗	✗	✗	✗	✗	✗	✗
TP Sensor	✗	✗	✓	✗	✗	✗	✗	✗	✗	✗	✗
T2B Sensor	✗	✗	✗	✓	✗	✗	✗	✗	✗	✗	✗
Reactor	✗	✗	✗	✗	✗	✗	✗	✓	✗	✗	✗
Compressor	✗	✗	✗	✗	✗	✗	✓	✗	✗	✗	✓
IPM module board	✗	✗	✗	✗	✗	✗	✓	✓	✓	✗	✓
High pressure protector	✗	✗	✗	✗	✗	✗	✗	✗	✓	✗	✗
Low pressure protector	✗	✗	✗	✗	✗	✗	✗	✗	✗	✓	✗
Additional refrigerant	✗	✗	✗	✗	✗	✗	✗	✗	✗	✓	✗

**Note:** For certain models, outdoor PCB could not be removed separately. In this case, the outdoor electric control box should be replaced as a whole.

---

## 7. Troubleshooting by Error Code

### 7.1 E0/EH 00 / F4/EC 51 (EEPROM parameter error diagnosis and solution)

**Description:** Indoor or outdoor PCB main chip does not receive feedback from EEPROM chip.

**Recommended parts to prepare:**

Indoor PCB

Outdoor PCB

**Troubleshooting and repair:**

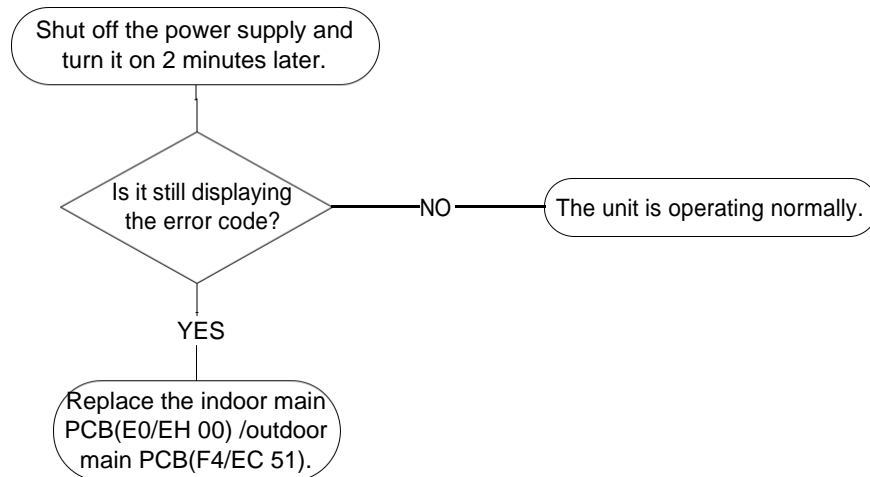

**Remarks:**

**EEPROM:** A read-only memory whose contents can be erased and reprogrammed using a pulsed voltage.

The location of the EEPROM chip on the indoor and outdoor PCB is shown in the following two images:

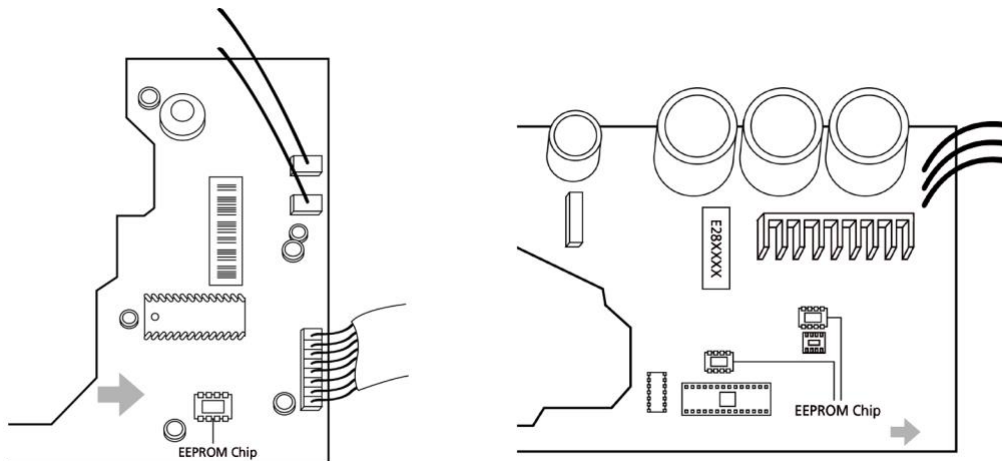

**Note:** For certain models, outdoor PCB could not be removed separately. In this case, the outdoor electric control box should be replaced as a whole. This pictures are only for reference, actual appearance may vary.

Troubleshooting and repair of compressor driven chip EEPROM parameter error and communication error between outdoor main chip and compressor driven chip are same as F4/EC 51.

## 7.2 E1/EL 01 (Indoor and outdoor unit communication error diagnosis and solution)

**Description:** Indoor unit can not communicate with outdoor unit

**Recommended parts to prepare:**

- Indoor PCB
- Outdoor PCB
- Short-circuited component

**Troubleshooting and repair:**

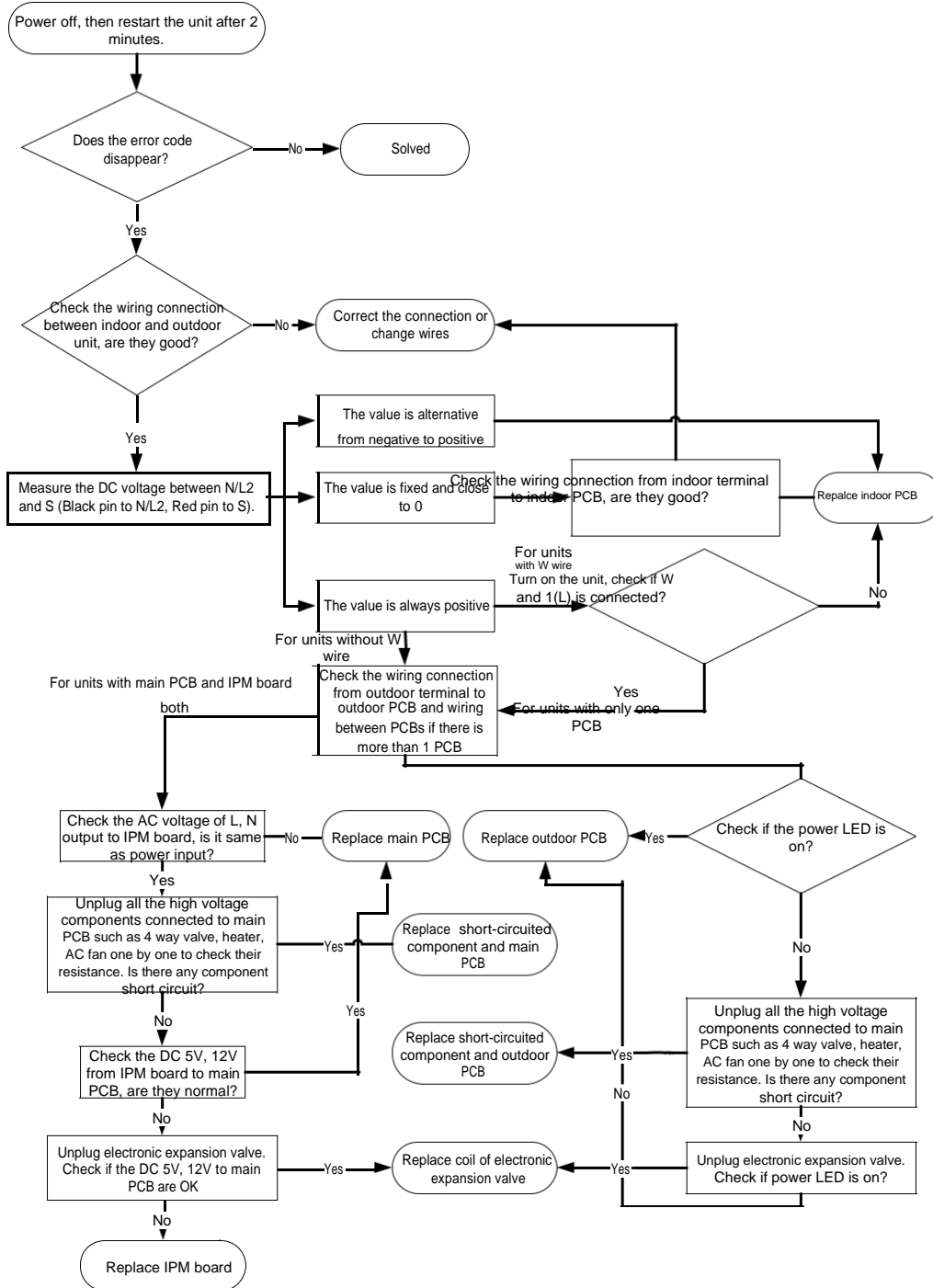

**Note:** For certain models, outdoor PCB could not be removed separately. In this case, the outdoor electric control box should be replaced as a whole.



---

**Remarks:**

Use a multimeter to test the DC voltage between 2 port(or S or L2 port) and 3 port(or N or S port) of outdoor unit.  
The red pin of multimeter connects with 2 port(or S or L2 port) while the black pin is for 3 port(or N or S port) .  
When AC is normal running, the voltage is moving alternately as positive values and negative values  
If the outdoor unit has malfunction, the voltage has always been the positive value.  
While if the indoor unit has malfunction, the voltage has always been a certain value.

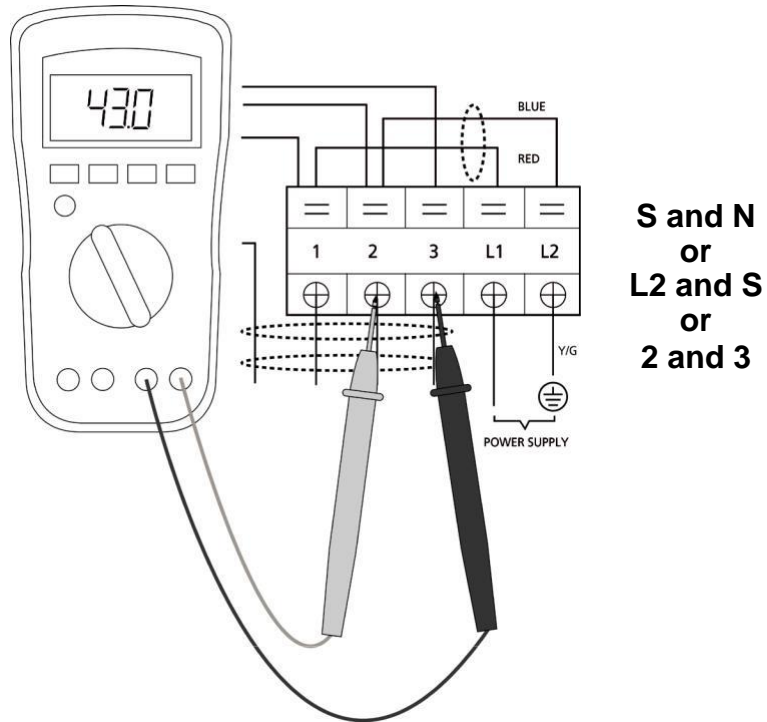

Use a multimeter to test the resistance of the reactor which does not connect with capacitor.  
The normal value should be around zero ohm. Otherwise, the reactor must have malfunction.

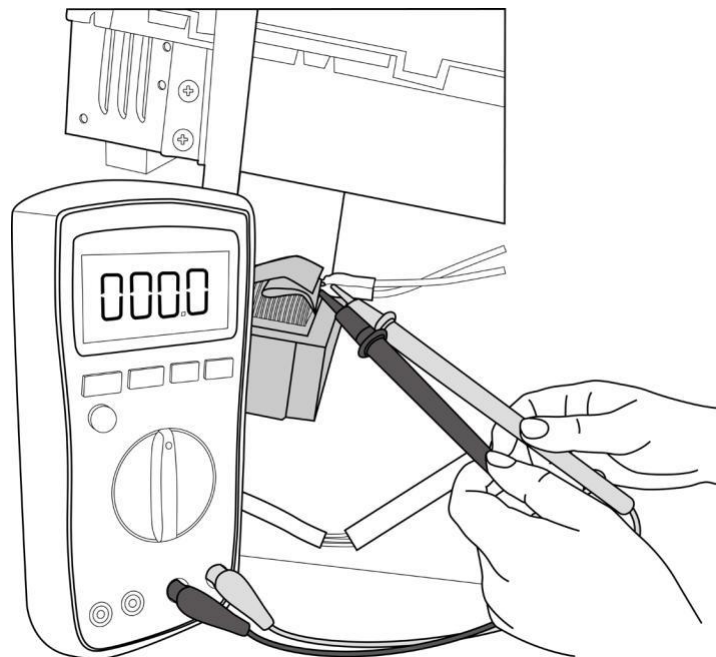

**Note:** The picture and the value are only for reference, actual condition and specific value may vary.

---

### 7.3 E2/EH 02 (Zero crossing detection error diagnosis and solution)

**Description:** When PCB does not receive zero crossing signal feedback for 4 minutes or the zero crossing signal time interval is abnormal.

**Recommended parts to prepare:**

Connection wires

PCB

**Troubleshooting and repair:**

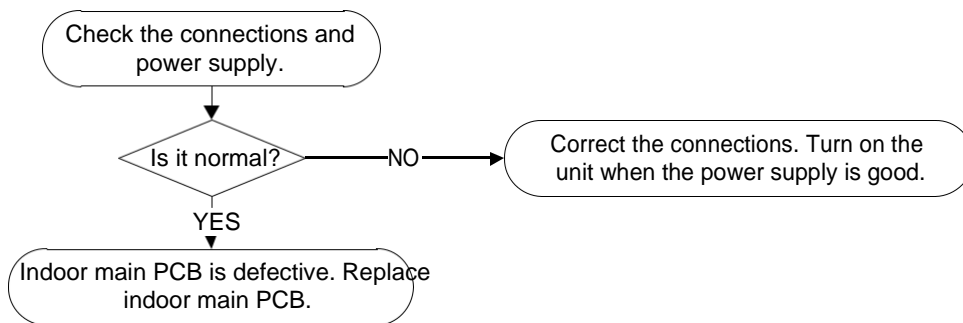

**Note:** E2/EH 02 zero crossing detection error is only valid for the unit with AC fan motor, for other models, this error is invalid.

## 7.4 E3/EH 03 / F5/EC 07 (Fan speed is operating outside of normal range diagnosis and solution)

**Description:** When indoor / outdoor fan speed keeps too low or too high for a certain time, the LED displays the failure code and the AC turns off.

### Recommended parts to prepare:

- Connection wires
- Fan assembly
- Fan motor
- PCB

### Troubleshooting and repair:

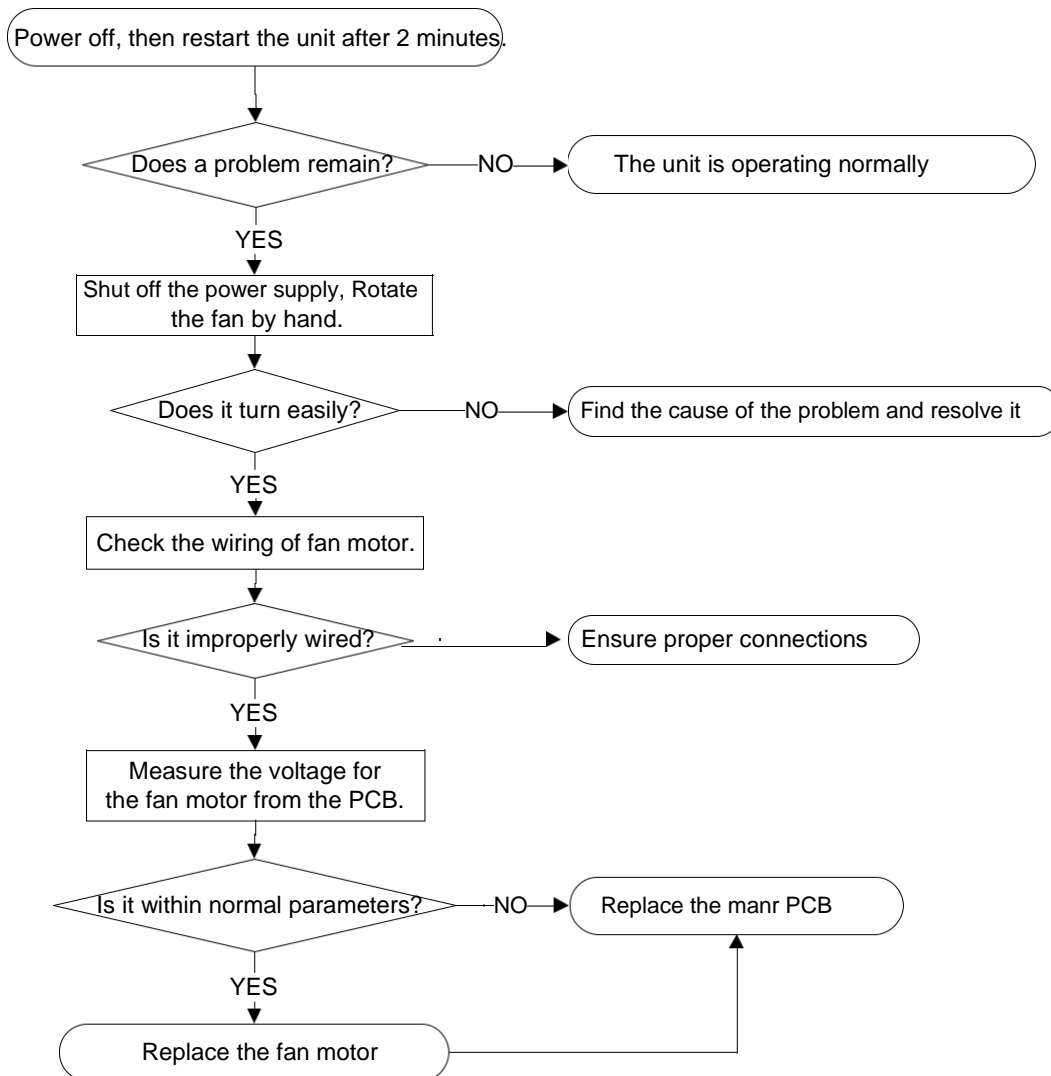

**Note:** For certain models, outdoor PCB could not be removed separately. In this case, the outdoor electric control box should be replaced as a whole.

---

## Index:

### 1. Indoor or Outdoor DC Fan Motor(control chip is in fan motor)

Power on and when the unit is in standby, measure the voltage of pin1-pin3, pin4-pin3 in fan motor connector. If the value of the voltage is not in the range showing in below table, the PCB must has problems and need to be replaced.

- DC motor voltage input and output (voltage: 220-240V~):

No.	Color	Signal	Voltage
1	Red	Vs/Vm	280V~380V
2	---	---	---
3	Black	GND	0V
4	White	Vcc	14-17.5V
5	Yellow	Vsp	0~5.6V
6	Blue	FG	14-17.5V

- DC motor voltage input and output (voltage: 115V~):

No.	Color	Signal	Voltage
1	Red	Vs/Vm	140V~190V
2	---	---	---
3	Black	GND	0V
4	White	Vcc	14-17.5V
5	Yellow	Vsp	0~5.6V
6	Blue	FG	14-17.5V

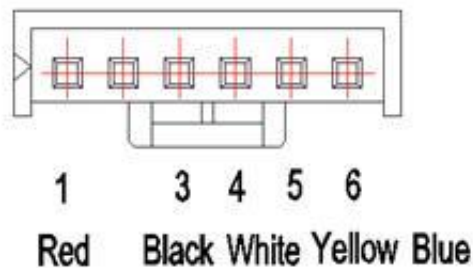

### 2. Outdoor DC Fan Motor (control chip is in outdoor PCB)

Release the UVW connector. Measure the resistance of U-V, U-W, V-W. If the resistance is not equal to each other, the fan motor must has problems and need to be replaced. otherwise the PCB must has problems and need to be replaced.

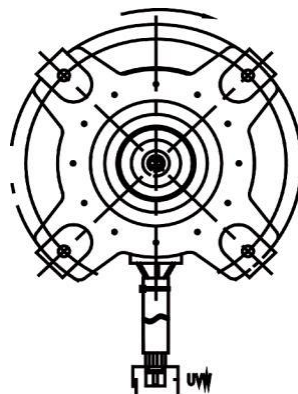

---

### 3. Indoor AC Fan Motor

Power on and set the unit running in fan mode at high fan speed. After running for 15 seconds, measure the voltage of pin1 and pin2. If the value of the voltage is less than 100V(208~240V power supply) or 50V (115V power supply), the PCB must has problems and need to be replaced.

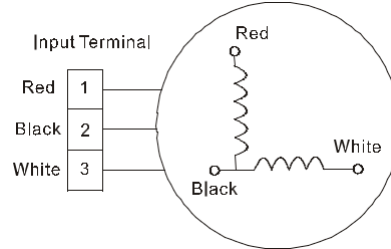

## 7.5 E4/EH 60/E5/EH 61/F1/EC 53/F2/EC 52/F3/EC 54/F6/EC56 (Open circuit or short circuit of temperature sensor diagnosis and solution)

**Description:** If the sampling voltage is lower than 0.06V or higher than 4.94V, the LED displays the failure code.

### Recommended parts to prepare:

Connection wires

Sensors

PCB

### Troubleshooting and repair:

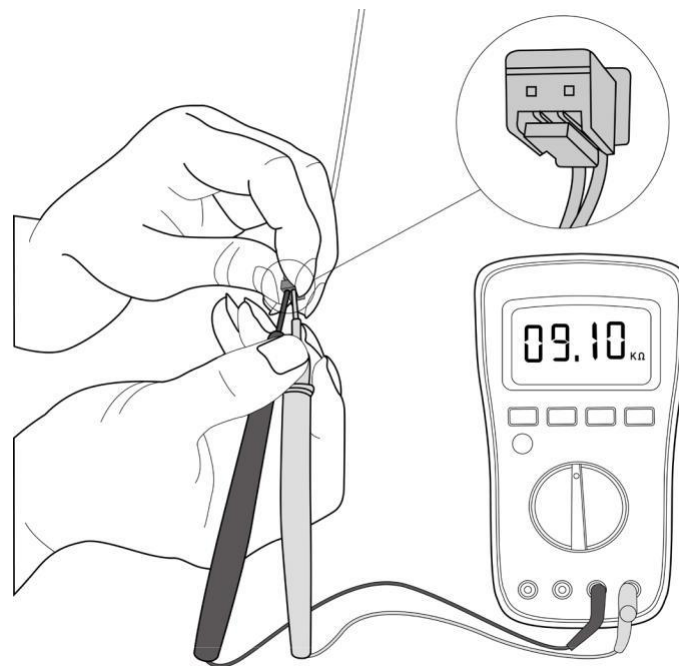
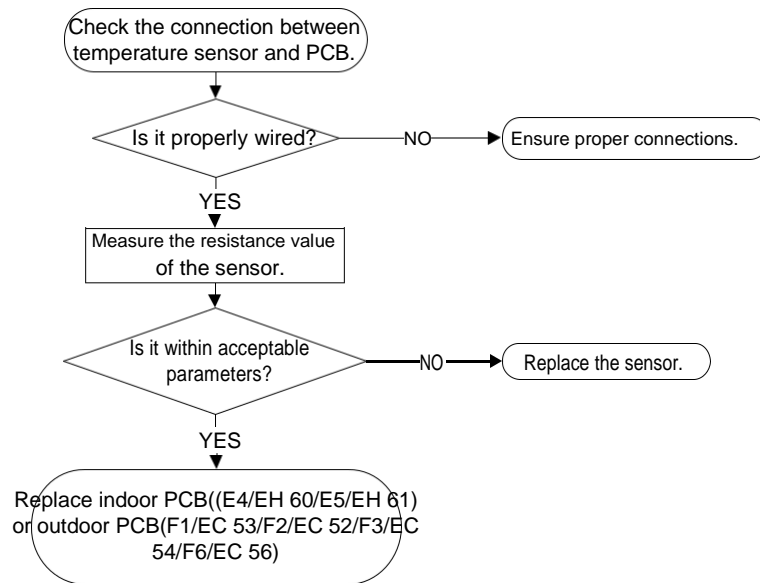

**Note:** For certain models, outdoor PCB could not be removed separately. In this case, the outdoor electric control box should be replaced as a whole. This picture and the value are only for reference, actual appearance and value may vary. For certain models, outdoor unit uses combination sensor, T3,T4 and TP are the same of sensor.

---

## 7.6 E7/EH 0b (Indoor PCB / Display board communication error diagnosis and solution)

**Description:** Indoor PCB does not receive feedback from the display board.

**Recommended parts to prepare:**

Communication wire

Indoor PCB

Display board

**Troubleshooting and repair:**

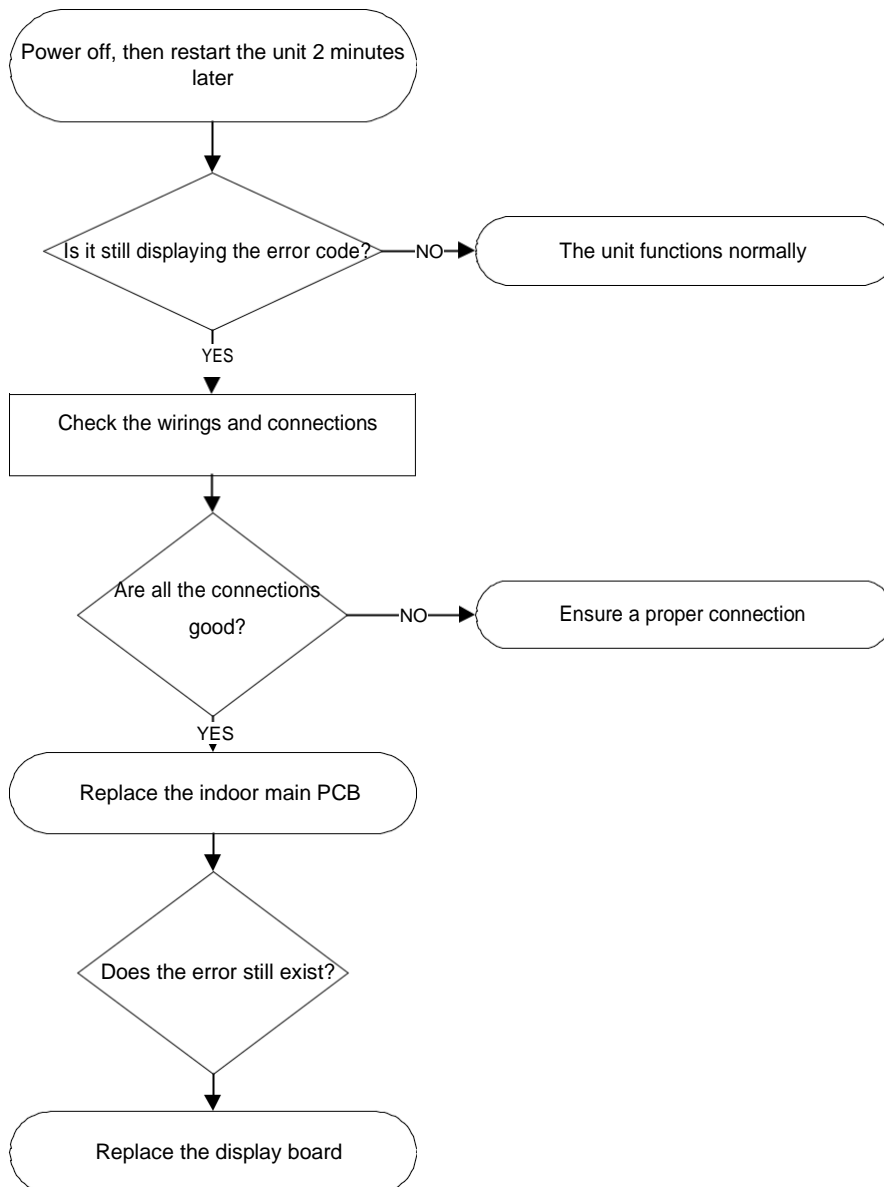

## 7.7 EC/EL 0C (Refrigerant Leakage Detection diagnosis and solution)

**Description:** Define the evaporator coil temperature T2 of the compressor just starts running as Tcool.

In the beginning 5 minutes after the compressor starts up, if  $T2 < T_{cool} - 1^{\circ}\text{C} (1.8^{\circ}\text{F})$  does not keep continuous 4 seconds and compressor running frequency higher than 50Hz does not keep for 3 minutes, and this situation happens 3 times, the LED displays the failure code and the AC turns off.

### Recommended parts to prepare:

- T2 sensor
- Indoor PCB
- Additional refrigerant

### Troubleshooting and repair:

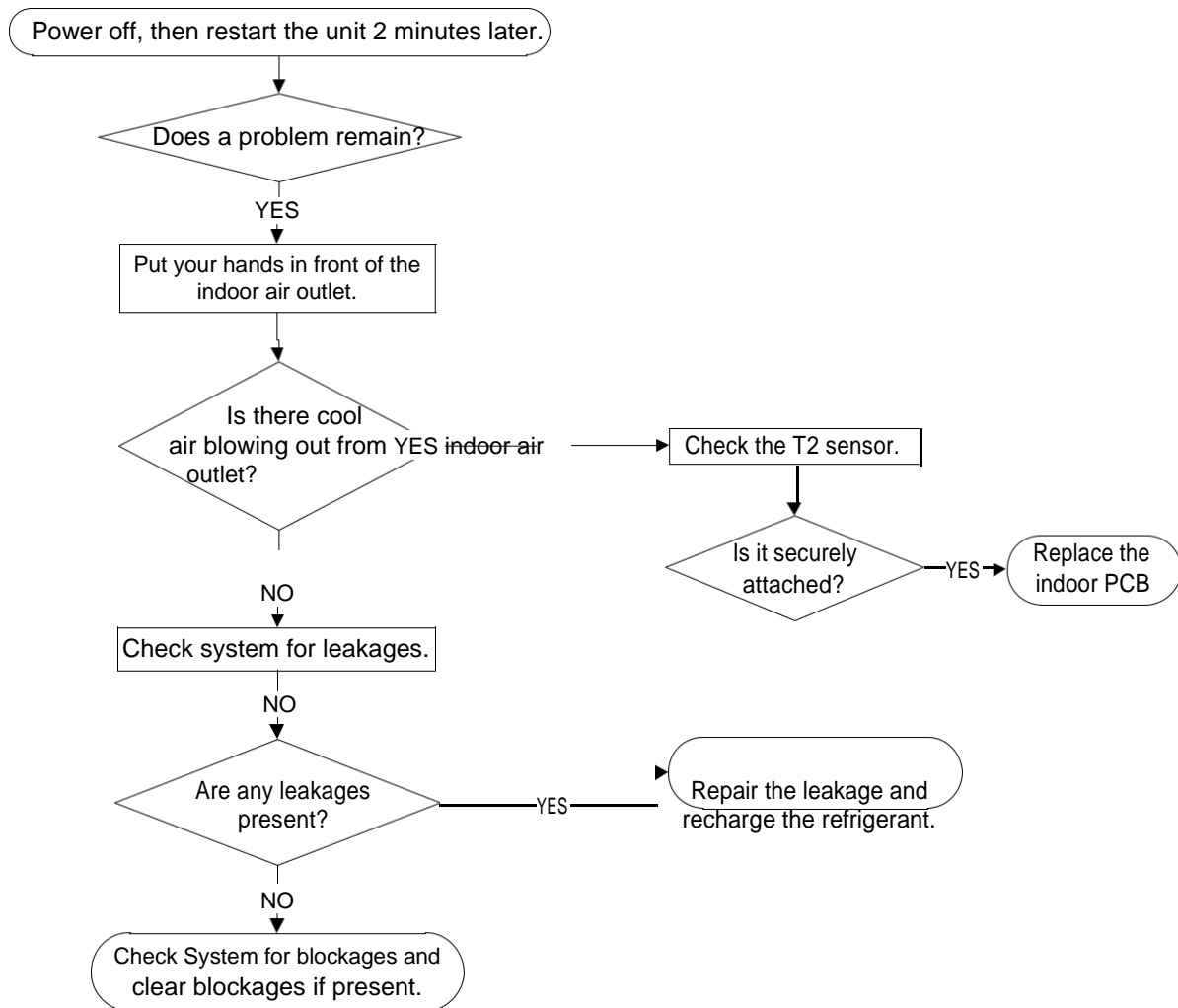



---

## 7.8 F0/PC 08 (Overload current protection diagnosis and solution)

**Description:** An abnormal current rise is detected by checking the specified current detection circuit.

**Recommended parts to prepare:**

- Outdoor PCB
- Connection wires
- Compressor

**Troubleshooting and repair:**

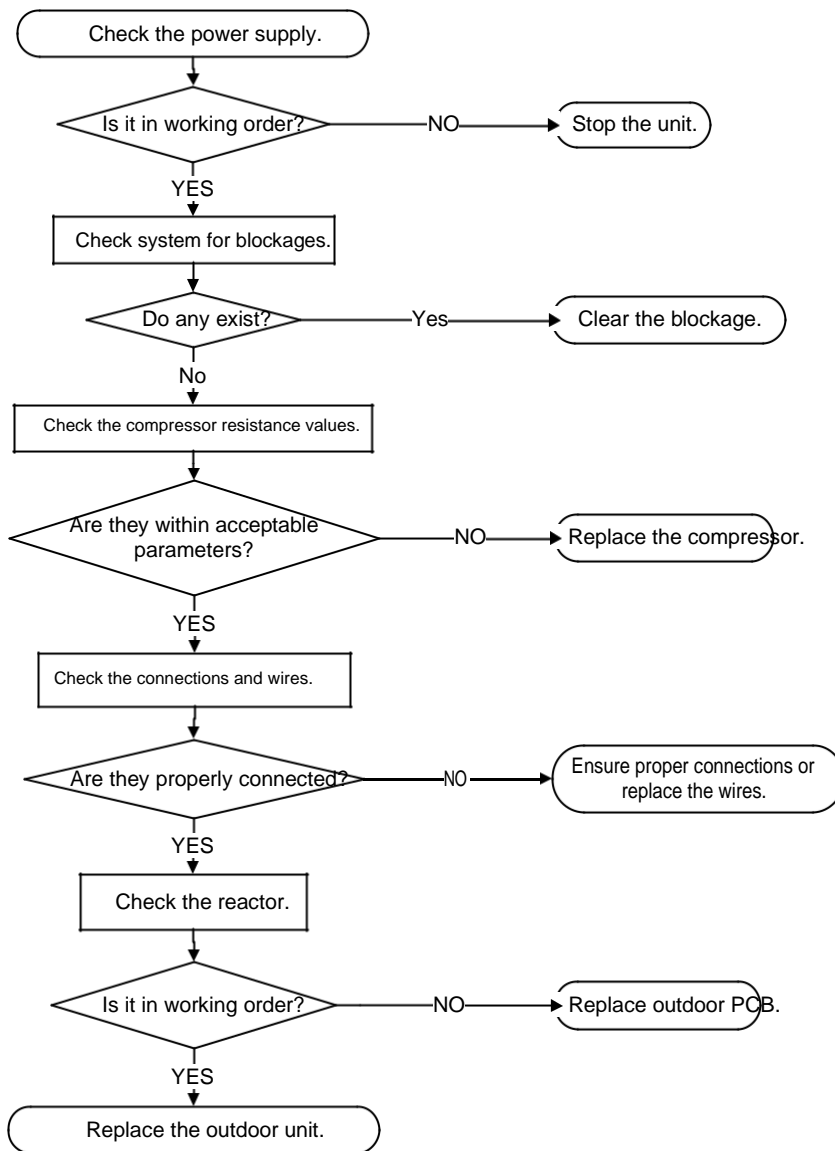

**Note:** For certain models, outdoor PCB could not be removed separately. In this case, the outdoor electric control box should be replaced as a whole.

## 7.9 P0/PC 00(IPM malfunction or IGBT over-strong current protection diagnosis and solution)

**Description:** When the voltage signal the IPM sends to the compressor drive chip is abnormal, the LED displays the failure code and the AC turns off.

### Recommended parts to prepare:

- Connection wires
- IPM module board
- Outdoor fan assembly
- Compressor
- Outdoor PCB

### Troubleshooting and repair:

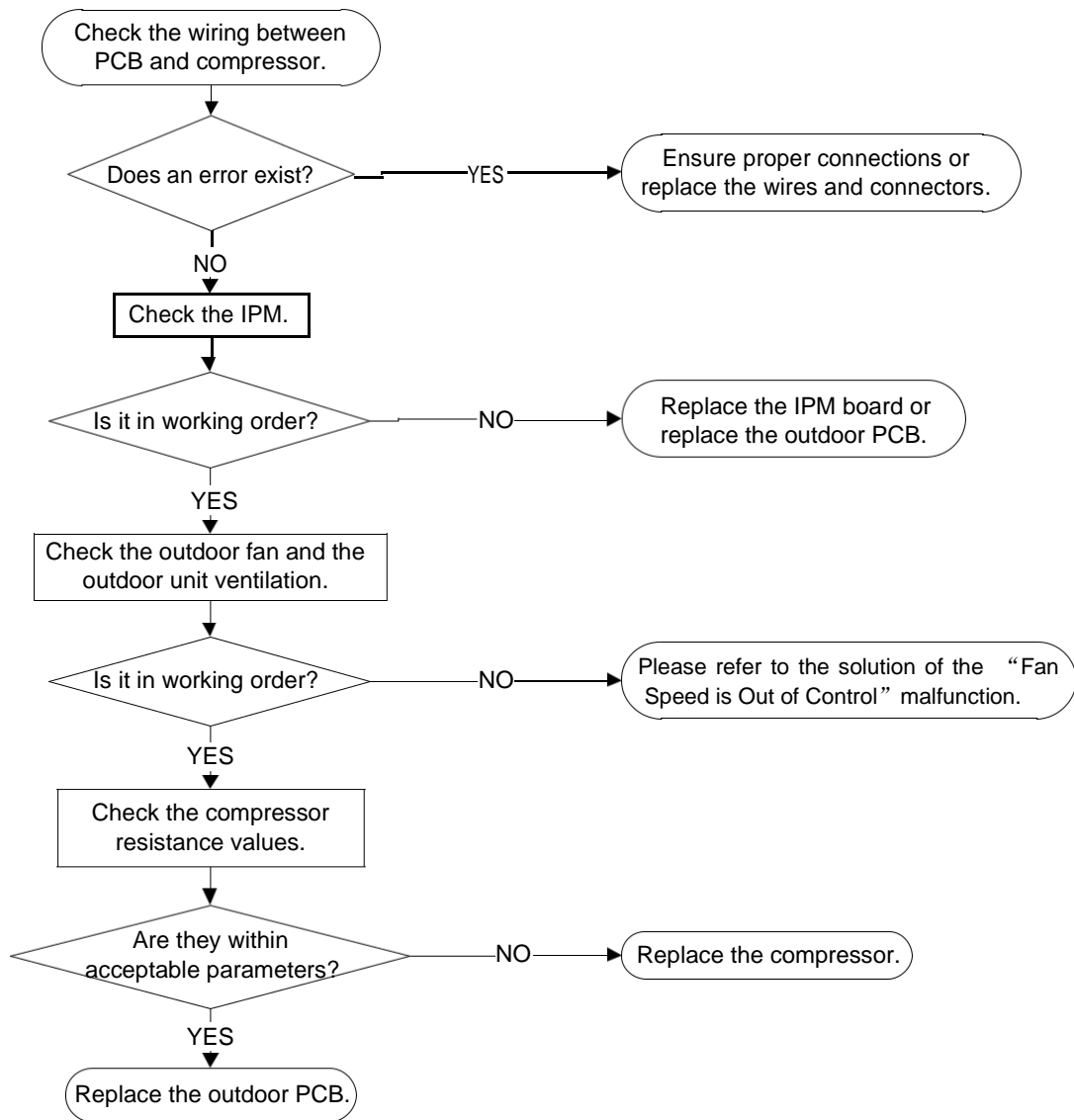

**Note:** For certain models, outdoor PCB could not be removed separately. In this case, the outdoor electric control box should be replaced as a whole.

---

## 7.10 P1/PC 01(Over voltage or too low voltage protection diagnosis and solution)

**Description:** Abnormal increases or decreases in voltage are detected by checking the specified voltage detection circuit.

**Recommended parts to prepare:**

- Power supply wires
- IPM module board
- PCB
- Reactor

**Troubleshooting and repair:**

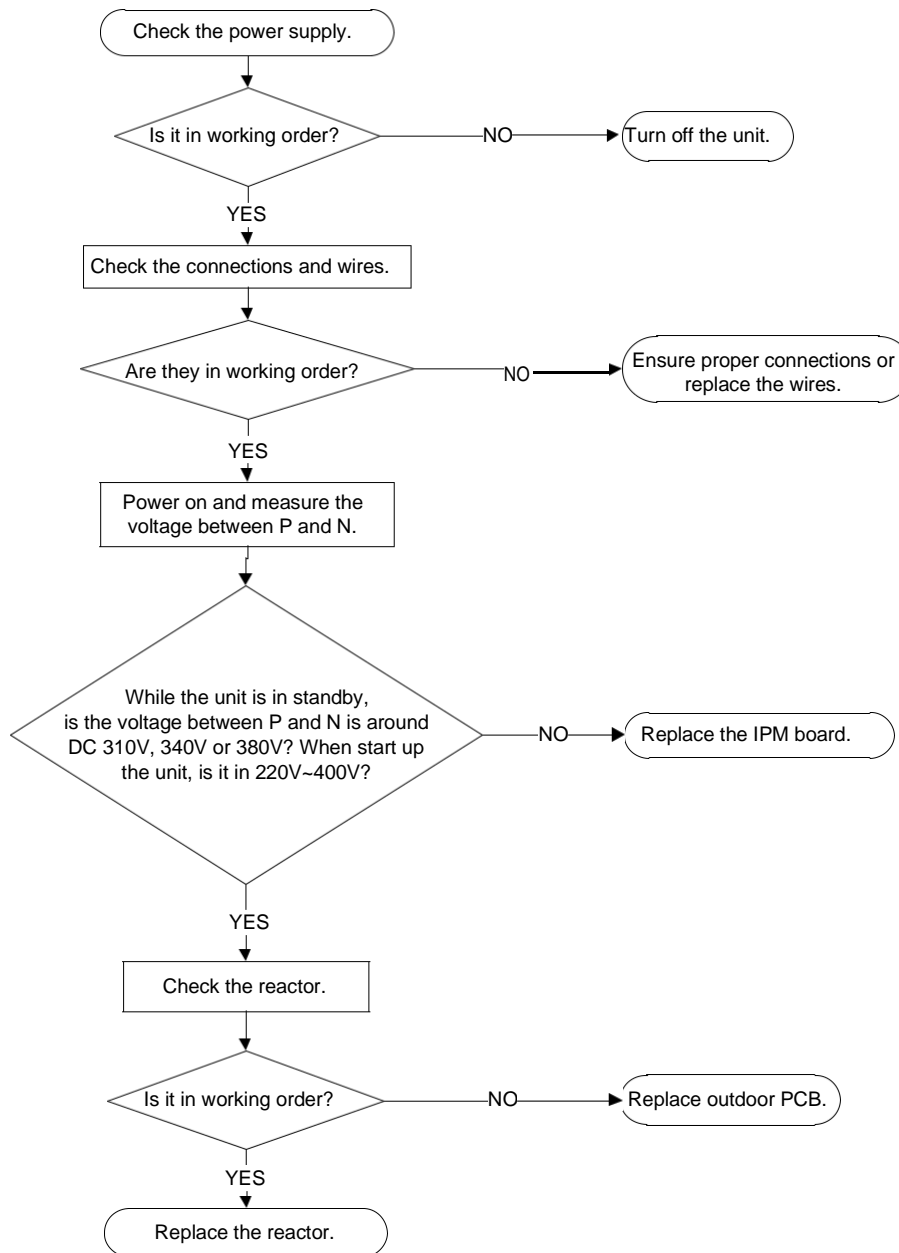

**Note:** For certain models, outdoor PCB could not be removed separately. In this case, the outdoor electric control box should be replaced as a whole.

---

## 7.11 P2/PC 02(High temperature protection of IPM module or High pressure protection diagnosis and solution)

**Description:** If the temperature of IPM module is higher than a certain value, the LED displays the failure code.

For some models with high pressure switch, outdoor pressure switch cut off the system because high pressure is higher than 4.4 MPa, the LED displays the failure code.

### Recommended parts to prepare:

- Connection wires
- Outdoor PCB
- IPM module board
- High pressure protector
- System blockages

### Troubleshooting and repair:

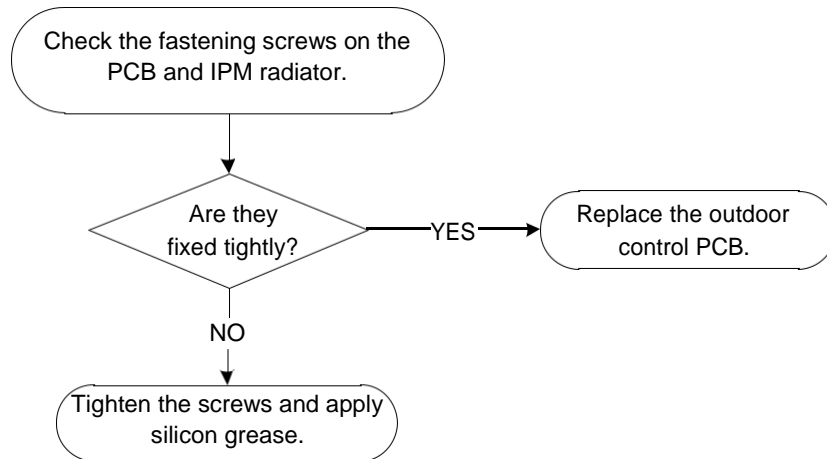

**Note:** For certain models, outdoor PCB could not be removed separately. In this case, the outdoor electric control box should be replaced as a whole.

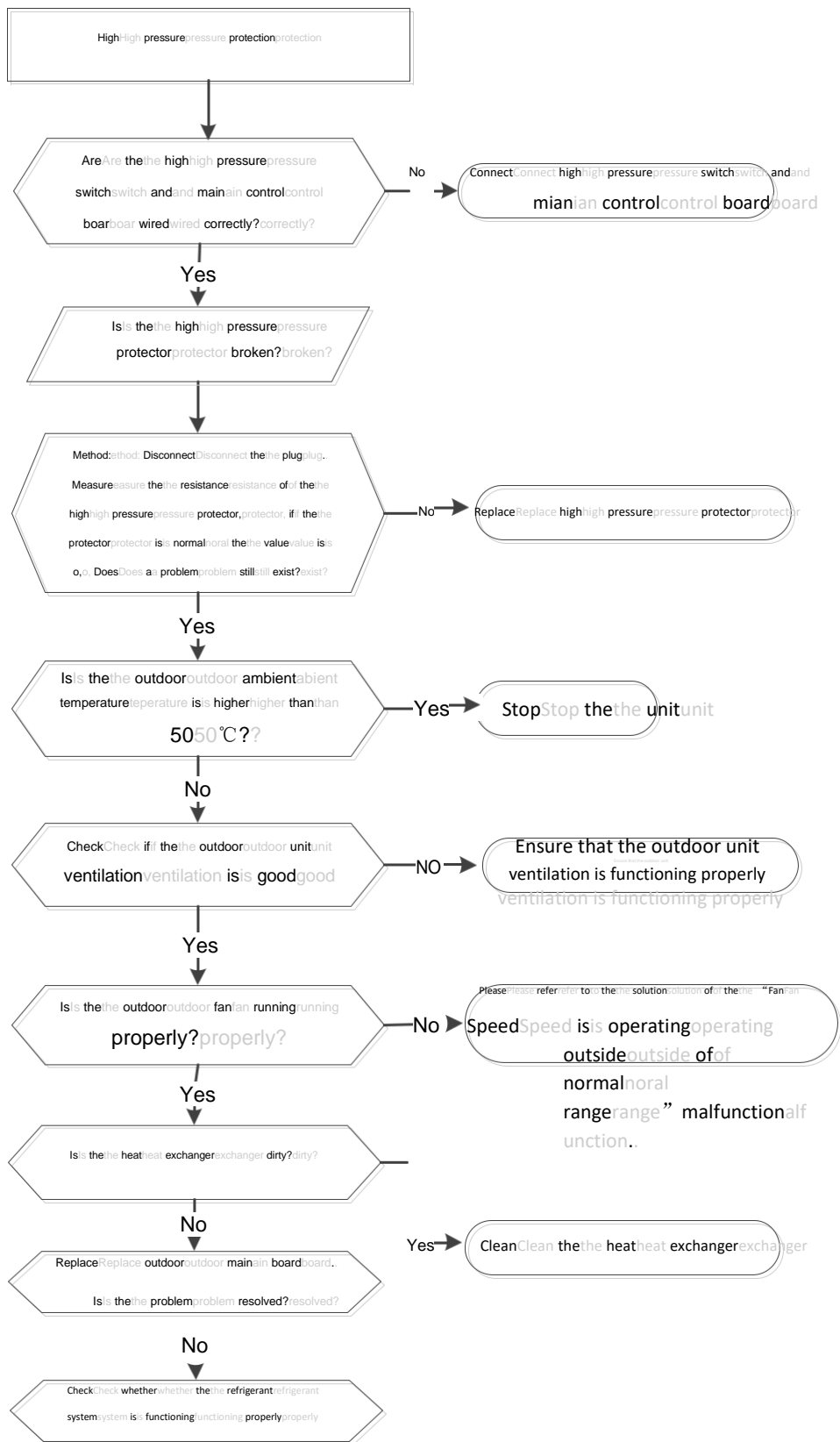

---

## 7.12 P4/PC 04(Inverter compressor drive error diagnosis and solution)

**Description:** An abnormal inverter compressor drive is detected by a special detection circuit, including communication signal detection, voltage detection, compressor rotation speed signal detection and so on.

**Recommended parts to prepare:**

- Connection wires
- IPM module board
- Outdoor fan assembly
- Compressor
- Outdoor PCB

**Troubleshooting and repair:**

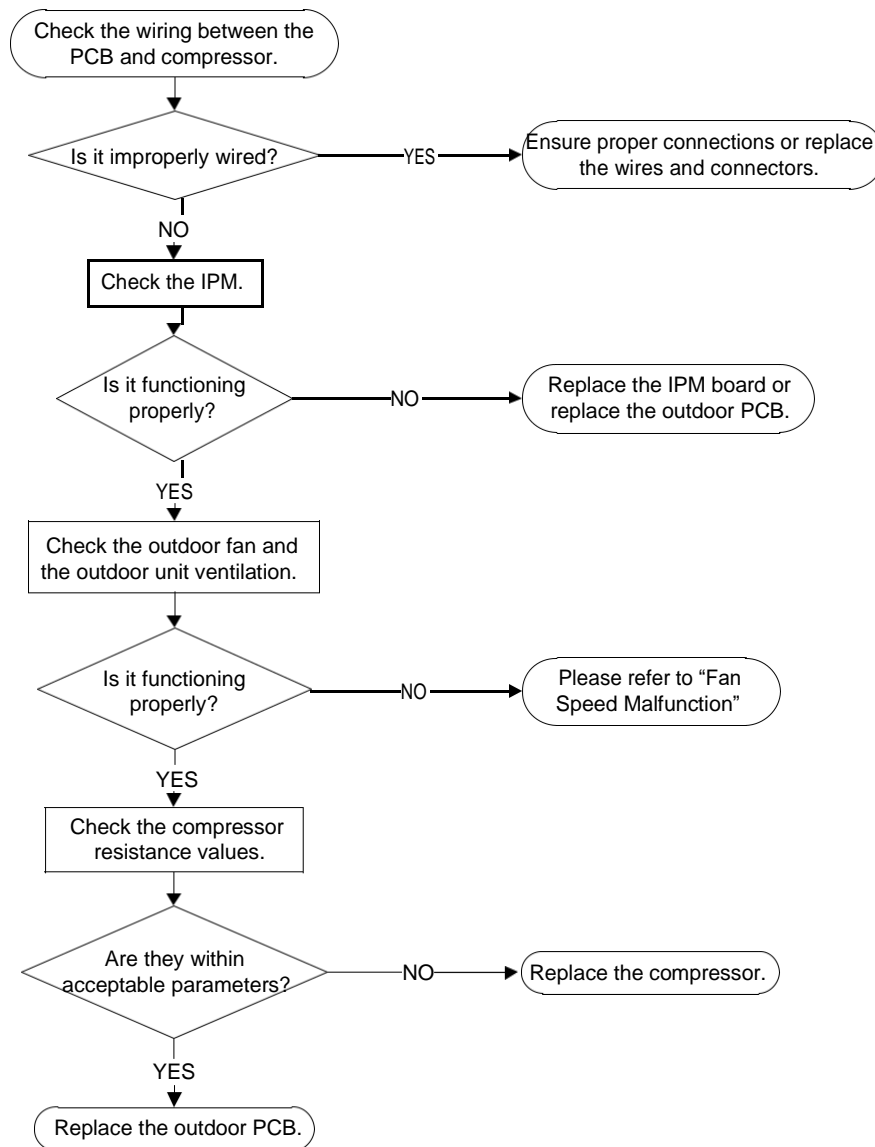

**Note:** For certain models, outdoor PCB could not be removed separately. In this case, the outdoor electric control box should be replaced as a whole.

---

### 7.13 PC 03(Low pressure protection diagnosis and solution)

**Description:** Outdoor pressure switch cut off the system because low pressure is lower than 0.13 MPa, the LED displays the failure code.

**Recommended parts to prepare:**

- Connection wires
- Outdoor PCB
- Low pressure protector
- Refrigerant

**Troubleshooting and repair:**

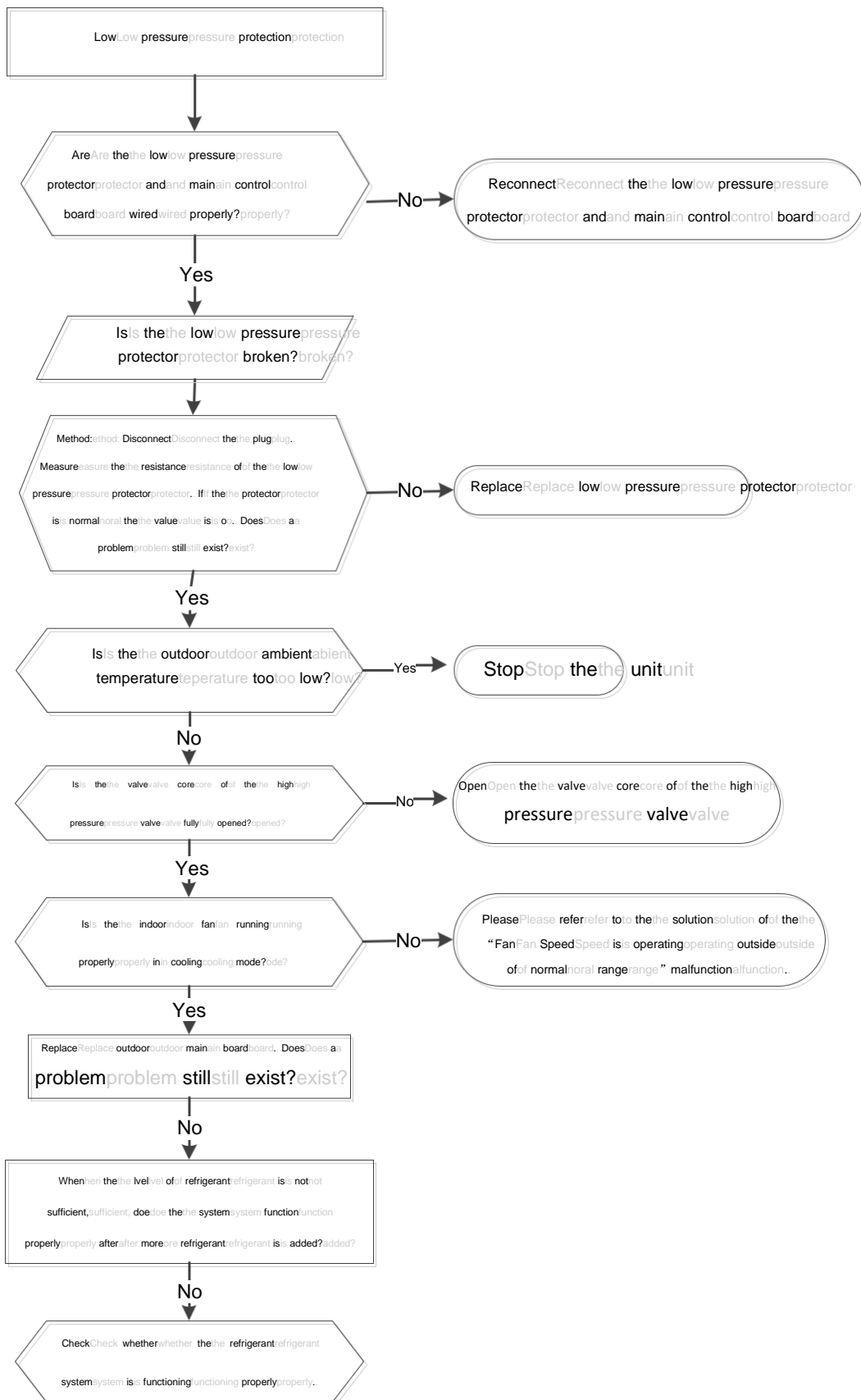



## 8. Check Procedures

### 8.1 Temperature Sensor Check

#### WARNING

**Be sure to turn off all power supplies or disconnect all wires to avoid electric shock. Operate after compressor and coil have returned to normal temperature in case of injury.**

Disconnect the temperature sensor from PCB (Refer to Chapter 5&6. Indoor&Outdoor Unit Disassembly).

Measure the resistance value of the sensor using a multi-meter.

Check corresponding temperature sensor resistance value table (Refer to Chapter 8. Appendix).

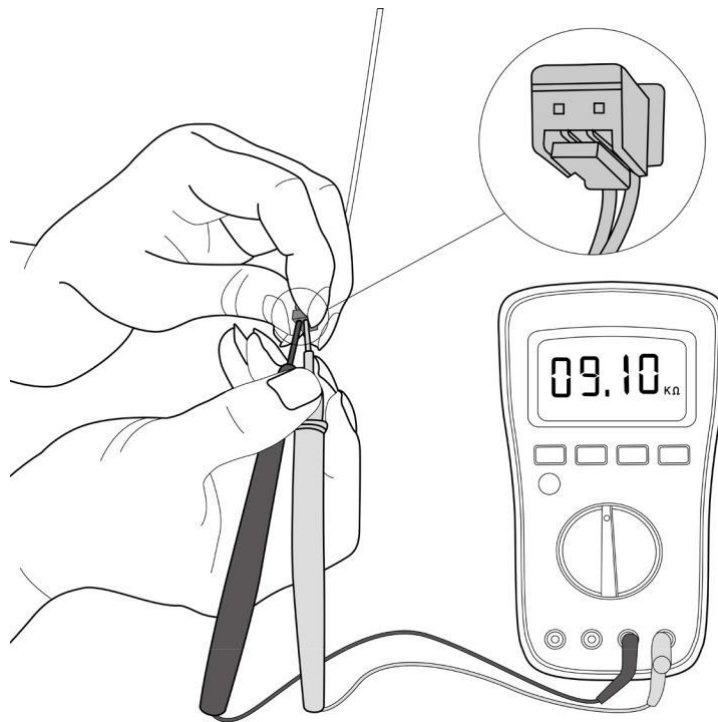

**Note:** The picture and the value are only for reference, actual condition and specific value may vary.

### .2 Compressor Check

Disconnect the compressor power cord from outdoor PCB (Refer to Chapter 6. Outdoor Unit Disassembly)).

Measure the resistance value of each winding using a multi-meter.

Check the resistance value of each winding in the following table.

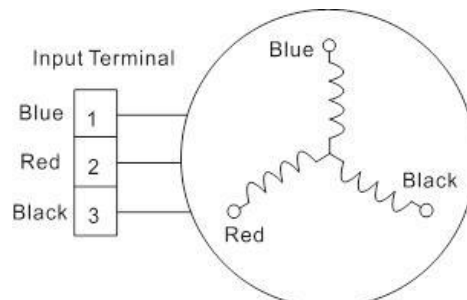

Resistance Value	KSK89D53UEZ	KSK89D29UEZD	KSN98D22UFZ	KSK103D33UEZ3	KTN150D30UFZA
Blue-Red	2.35Ω	1.99Ω	1.57Ω	2.13Ω	1.02Ω
Blue-Black					
Red-Black					

Resistance Value	KSM135D23UFZ	KSN140D21UFZ	KTF235D22UMT	KSK103D33UEZ3(YJ)	KTM240D57UMT
Blue-Red	1.72Ω	1.28Ω	0.75Ω	2.13Ω	0.62Ω
Blue-Black					
Red-Black					

Resistance Value	KSN140D58UFZ	KTM240D43UKT	KSN98D64UFZ3
Blue-Red	1.86Ω	1.03Ω	2.7Ω
Blue-Black			
Red-Black			

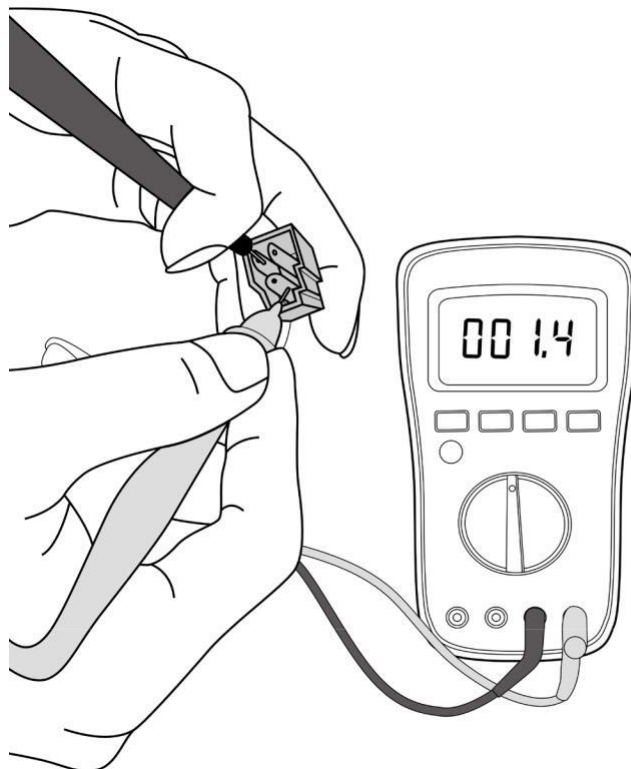

**Note:** The picture and the value are only for reference, actual condition and specific value may vary.

### 8.3 IPM Continuity Check

#### **!** WARNING

**Electricity remains in capacitors even when the power supply is off.  
Ensure the capacitors are fully discharged before troubleshooting.**

Turn off outdoor unit and disconnect power supply.

Discharge electrolytic capacitors and ensure all energy-storage unit has been discharged.

Disassemble outdoor PCB or disassemble IPM board.

Measure the resistance value between P and U(V, W, N); U(V, W) and N.

Digital tester		Resistance value	Digital tester		Resistance value
(+)Red	(-)Black		(+)Red	(-)Black	
P	N	∞ (Several MΩ)	U	N	∞ (Several MΩ)
	U		V		
	V		W		
	W		-		

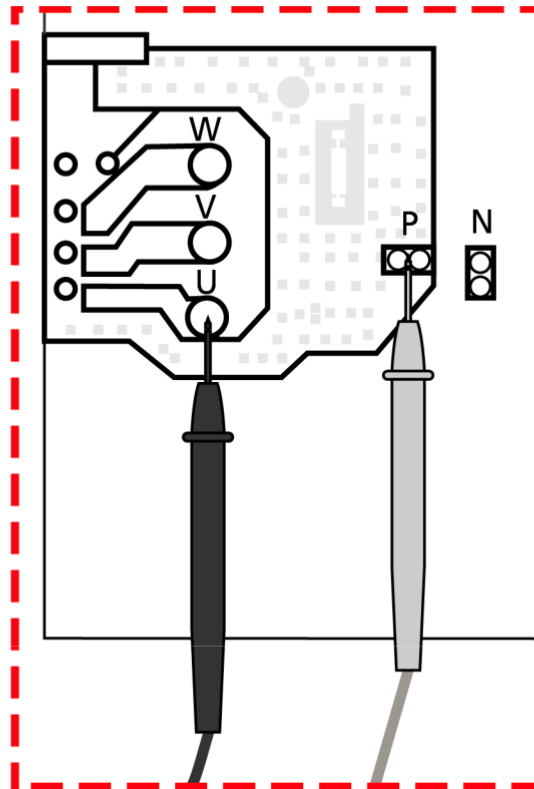

**Note:** The picture and the value are only for reference, actual condition and specific value may vary.

---

## 8.4 Fan Motor Check

Turn off outdoor unit and disconnect power supply

Disconnect outdoor fan motor power cord from outdoor PCB

Measure the resistance value between each windings.

The normal value of different motor show as follows:

Model	YKFG-13-4-38L YKFG-13-4-38L-4	YKFG-15-4-28-1	YKFG-20-4-10L	YKFG-20-4-5-11
Brand	Welling	Welling	Welling	Welling
Black – Red Main	345Ω	75Ω	269Ω	388Ω
Blue – Black AUX	348Ω	150Ω	224Ω	360Ω

Model	YKFG-20-4-5-19	YKFG-25-4-6-14	YKFG-28-4-3-7 YKFG-28-4-3-14	YKFG-28-4-6-5
Brand	Welling	Welling	Welling	Welling
Black – Red Main	444Ω	287Ω	231Ω	183.6Ω
Blue – Black AUX	470Ω	409Ω	414Ω	206Ω

Model	YKFG-45-4-13	YKFG-45-4-22 YKFG-45-4-22-13	YKFG-60-4-2-6
Brand	Dongfang	Welling	Welling
Black – Red Main	125.2Ω	168Ω	96Ω
Blue – Black AUX	83.8Ω	141Ω	96Ω

---

# Appendix

## Contents

- i) Temperature Sensor Resistance Value Table for T1, T2, T3, and T4 (°C – K). 2
- ii) Temperature Sensor Resistance Value Table for TP (for some units)(°C --K) 3
- iii) Pressure On Service Port..... 4

**i) Temperature Sensor Resistance Value Table for T1,T2,T3 and T4 (°C – K)**

°C	°F	K Ohm	°C	°F	K Ohm	°C	°F	K Ohm	°C	°F	K Ohm
-20	-4	115.266	20	68	12.6431	60	140	2.35774	100	212	0.62973
-19	-2	108.146	21	70	12.0561	61	142	2.27249	101	214	0.61148
-18	0	101.517	22	72	11.5	62	144	2.19073	102	216	0.59386
-17	1	96.3423	23	73	10.9731	63	145	2.11241	103	217	0.57683
-16	3	89.5865	24	75	10.4736	64	147	2.03732	104	219	0.56038
-15	5	84.219	25	77	10	65	149	1.96532	105	221	0.54448
-14	7	79.311	26	79	9.55074	66	151	1.89627	106	223	0.52912
-13	9	74.536	27	81	9.12445	67	153	1.83003	107	225	0.51426
-12	10	70.1698	28	82	8.71983	68	154	1.76647	108	226	0.49989
-11	12	66.0898	29	84	8.33566	69	156	1.70547	109	228	0.486
-10	14	62.2756	30	86	7.97078	70	158	1.64691	110	230	0.47256
-9	16	58.7079	31	88	7.62411	71	160	1.59068	111	232	0.45957
-8	18	56.3694	32	90	7.29464	72	162	1.53668	112	234	0.44699
-7	19	52.2438	33	91	6.98142	73	163	1.48481	113	235	0.43482
-6	21	49.3161	34	93	6.68355	74	165	1.43498	114	237	0.42304
-5	23	46.5725	35	95	6.40021	75	167	1.38703	115	239	0.41164
-4	25	44	36	97	6.13059	76	169	1.34105	116	241	0.4006
-3	27	41.5878	37	99	5.87359	77	171	1.29078	117	243	0.38991
-2	28	39.8239	38	100	5.62961	78	172	1.25423	118	244	0.37956
-1	30	37.1988	39	102	5.39689	79	174	1.2133	119	246	0.36954
0	32	35.2024	40	104	5.17519	80	176	1.17393	120	248	0.35982
1	34	33.3269	41	106	4.96392	81	178	1.13604	121	250	0.35042
2	36	31.5635	42	108	4.76253	82	180	1.09958	122	252	0.3413
3	37	29.9058	43	109	4.5705	83	181	1.06448	123	253	0.33246
4	39	28.3459	44	111	4.38736	84	183	1.03069	124	255	0.3239
5	41	26.8778	45	113	4.21263	85	185	0.99815	125	257	0.31559
6	43	25.4954	46	115	4.04589	86	187	0.96681	126	259	0.30754
7	45	24.1932	47	117	3.88673	87	189	0.93662	127	261	0.29974
8	46	22.5662	48	118	3.73476	88	190	0.90753	128	262	0.29216
9	48	21.8094	49	120	3.58962	89	192	0.8795	129	264	0.28482
10	50	20.7184	50	122	3.45097	90	194	0.85248	130	266	0.2777
11	52	19.6891	51	124	3.31847	91	196	0.82643	131	268	0.27078
12	54	18.7177	52	126	3.19183	92	198	0.80132	132	270	0.26408
13	55	17.8005	53	127	3.07075	93	199	0.77709	133	271	0.25757
14	57	16.9341	54	129	2.95896	94	201	0.75373	134	273	0.25125
15	59	16.1156	55	131	2.84421	95	203	0.73119	135	275	0.24512
16	61	15.3418	56	133	2.73823	96	205	0.70944	136	277	0.23916
17	63	14.6181	57	135	2.63682	97	207	0.68844	137	279	0.23338
18	64	13.918	58	136	2.53973	98	208	0.66818	138	280	0.22776
19	66	13.2631	59	138	2.44677	99	210	0.64862	139	282	0.22231

**ii) Temperature Sensor Resistance Value Table for TP(for some units) (°C --K)**

°C	°F	K Ohm	°C	°F	K Ohm	°C	°F	K Ohm	°C	°F	K Ohm
-20	-4	542.7	20	68	68.66	60	140	13.59	100	212	3.702
-19	-2	511.9	21	70	65.62	61	142	13.11	101	214	3.595
-18	0	483	22	72	62.73	62	144	12.65	102	216	3.492
-17	1	455.9	23	73	59.98	63	145	12.21	103	217	3.392
-16	3	430.5	24	75	57.37	64	147	11.79	104	219	3.296
-15	5	406.7	25	77	54.89	65	149	11.38	105	221	3.203
-14	7	384.3	26	79	52.53	66	151	10.99	106	223	3.113
-13	9	363.3	27	81	50.28	67	153	10.61	107	225	3.025
-12	10	343.6	28	82	48.14	68	154	10.25	108	226	2.941
-11	12	325.1	29	84	46.11	69	156	9.902	109	228	2.86
-10	14	307.7	30	86	44.17	70	158	9.569	110	230	2.781
-9	16	291.3	31	88	42.33	71	160	9.248	111	232	2.704
-8	18	275.9	32	90	40.57	72	162	8.94	112	234	2.63
-7	19	261.4	33	91	38.89	73	163	8.643	113	235	2.559
-6	21	247.8	34	93	37.3	74	165	8.358	114	237	2.489
-5	23	234.9	35	95	35.78	75	167	8.084	115	239	2.422
-4	25	222.8	36	97	34.32	76	169	7.82	116	241	2.357
-3	27	211.4	37	99	32.94	77	171	7.566	117	243	2.294
-2	28	200.7	38	100	31.62	78	172	7.321	118	244	2.233
-1	30	190.5	39	102	30.36	79	174	7.086	119	246	2.174
0	32	180.9	40	104	29.15	80	176	6.859	120	248	2.117
1	34	171.9	41	106	28	81	178	6.641	121	250	2.061
2	36	163.3	42	108	26.9	82	180	6.43	122	252	2.007
3	37	155.2	43	109	25.86	83	181	6.228	123	253	1.955
4	39	147.6	44	111	24.85	84	183	6.033	124	255	1.905
5	41	140.4	45	113	23.89	85	185	5.844	125	257	1.856
6	43	133.5	46	115	22.89	86	187	5.663	126	259	1.808
7	45	127.1	47	117	22.1	87	189	5.488	127	261	1.762
8	46	121	48	118	21.26	88	190	5.32	128	262	1.717
9	48	115.2	49	120	20.46	89	192	5.157	129	264	1.674
10	50	109.8	50	122	19.69	90	194	5	130	266	1.632
11	52	104.6	51	124	18.96	91	196	4.849			
12	54	99.69	52	126	18.26	92	198	4.703			
13	55	95.05	53	127	17.58	93	199	4.562			
14	57	90.66	54	129	16.94	94	201	4.426			
15	59	86.49	55	131	16.32	95	203	4.294			
16	61	82.54	56	133	15.73	96	205	4.167			
17	63	78.79	57	135	15.16	97	207	4.045			
18	64	75.24	58	136	14.62	98	208	3.927			
19	66	71.86	59	138	14.09	99	210	3.812			

### iii) Pressure On Service Port

#### Cooling chart(R410A):

°F(°C)	ODU(DB)		0(-17)	5(-15)	15(-9.44)	45(7.22)	75(23.89)	85(29.44)	95(35)	105(40.56)	115(46.11)	120(48.89)
	IDU(DB/WB)											
BAR	70/59 (21.11/15)		6.4	6.5	7.3	8.0	8.2	7.8	8.1	8.6	10.1	10.6
	75/63 (23.89/17.22)		6.7	6.8	7.9	8.6	8.6	8.3	8.7	9.1	10.7	11.2
	80/67 (26.67/19.44)		7.1	7.2	8.5	9.5	9.3	8.9	9.1	9.6	11.2	11.9
	90/73 (32.22/22.78)		7.7	7.8	9.6	10.5	10.3	9.5	10.0	10.6	12.4	13.0
PSI	70/59 (21.11/15)		93	94	106	116	119	113	117	125	147	154
	75/63 (23.89/17.22)		97	99	115	125	124	120	126	132	155	162
	80/67 (26.67/19.44)		103	104	123	138	135	129	132	140	162	173
	90/73 (32.22/22.78)		112	113	139	152	149	138	145	154	180	189
MPa	70/59 (21.11/15)		0.64	0.65	0.73	0.8	0.82	0.78	0.81	0.86	1.01	1.06
	75/63 (23.89/17.22)		0.67	0.68	0.79	0.86	0.86	0.83	0.87	0.91	1.07	1.12
	80/67 (26.67/19.44)		0.71	0.72	0.85	0.95	0.93	0.89	0.91	0.96	1.12	1.19
	90/73 (32.22/22.78)		0.77	0.78	0.96	1.05	1.03	0.95	1	1.06	1.24	1.3

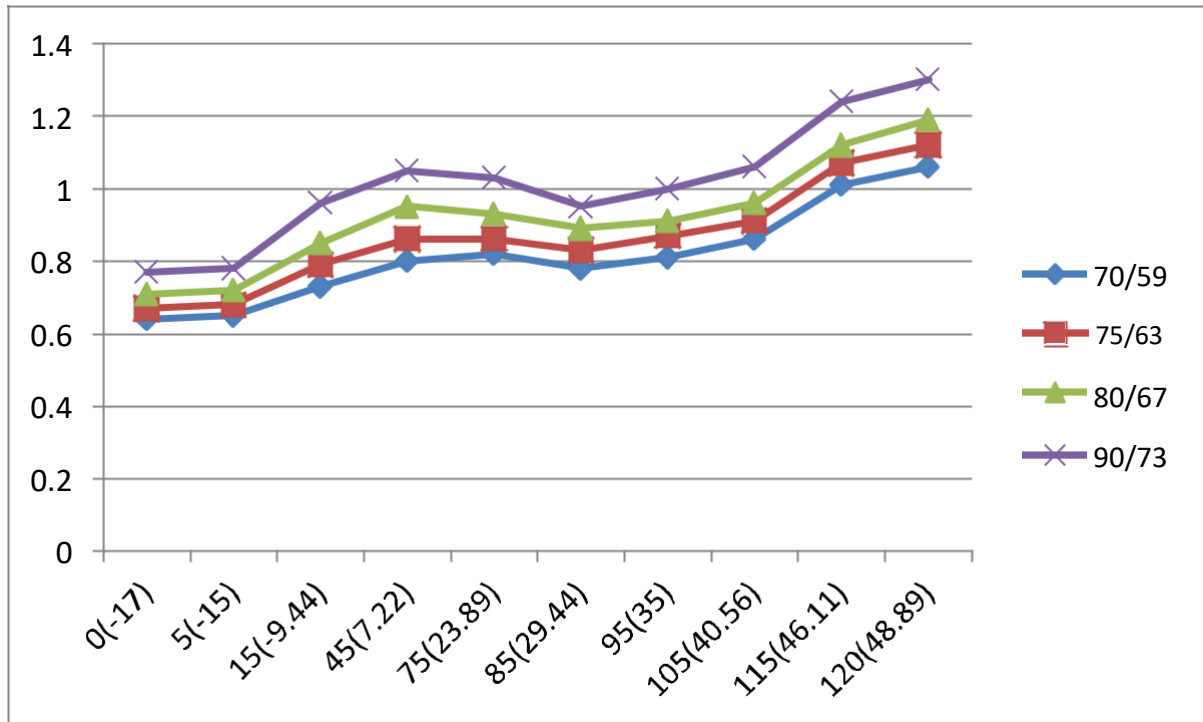



### Heating chart(R410A):

°F(°C)	ODU(DB/WB)	57/53 (13.89/11.67)	47/43 (8.33/6.11)	37/33 (2.78/0.56)	27/23 (-2.78/-5)	17/13 (-8.33/ -10.56)	0/-2 (-17/-19)	-17/-18 (-27/-28)
	IDU(DB)							
BAR	55(12.78)	30.3	28.5	25.3	22.8	20.8	18.5	16.5
	65(18.33)	32.5	30.0	26.6	25.4	23.3	20.5	19.0
	75(23.89)	33.8	31.5	27.8	26.3	24.9	21.5	20.0
PSI	55(12.78)	439	413	367	330	302	268	239
	65(18.33)	471	435	386	368	339	297	276
	75(23.89)	489	457	403	381	362	312	290
MPa	55(12.78)	3.03	2.85	2.53	2.28	2.08	1.85	1.65
	65(18.33)	3.25	3.00	2.66	2.54	2.33	2.05	1.90
	75(23.89)	3.38	3.15	2.78	2.63	2.49	2.15	2.00

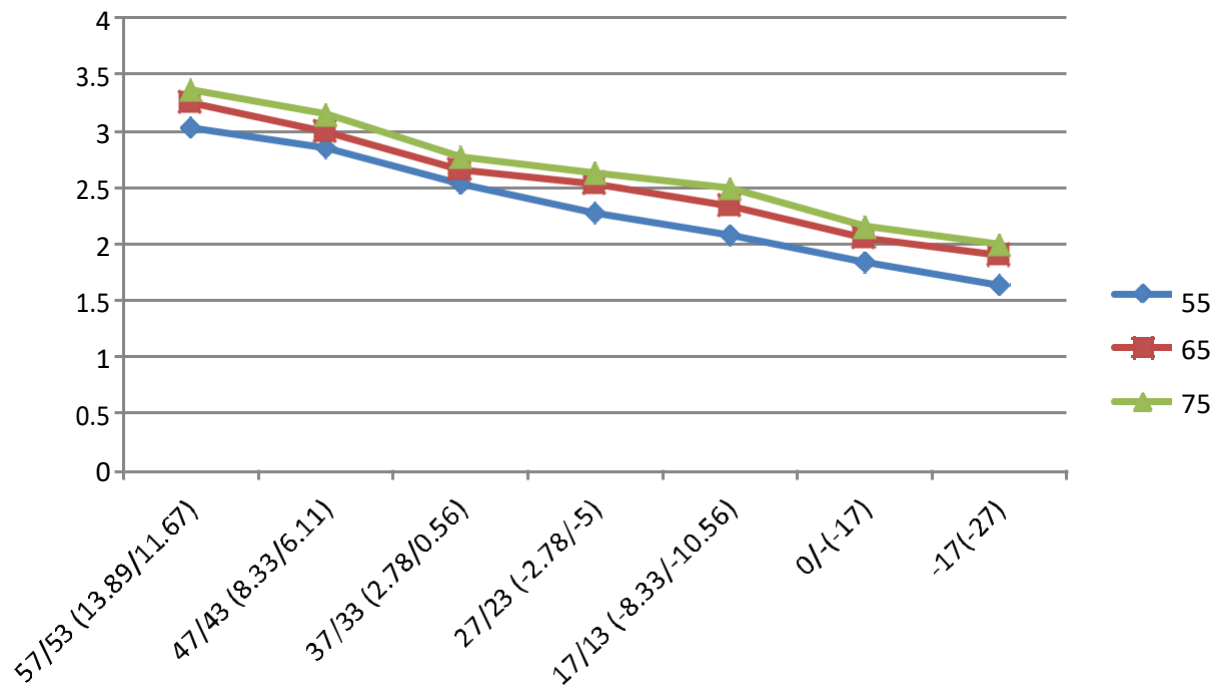

### Cooling chart(R22):

°F(°C)	ODU(DB)		0(-17)	5(-15)	15(-9.44)	45(7.22)	75(23.89)	85(29.44)	95(35)	105(40.56)	115(46.11)	120(48.89)
	IDU(DB/WB)											
BAR	70/59 (21.11/15)		4.0	4.1	4.6	5.0	5.1	4.9	5.1	5.4	6.3	6.6
	75/63 (23.89/17.22)		4.2	4.3	4.9	5.4	5.4	5.2	5.4	5.7	6.7	7.0
	80/67 (26.67/19.44)		4.4	4.5	5.3	5.9	5.8	5.6	5.7	6.0	7.0	7.4
	90/73 (32.22/22.78)		4.8	4.9	6.0	6.6	6.4	5.9	6.3	6.6	7.8	8.1
PSI	70/59 (21.11/15)		58	59	67	73	74	71	74	78	91	96
	75/63 (23.89/17.22)		61	62	71	78	78	75	78	83	97	102
	80/67 (26.67/19.44)		64	65	77	86	84	81	83	87	102	107
	90/73 (32.22/22.78)		70	71	87	96	93	86	91	96	113	117
MPa	70/59 (21.11/15)		0.40	0.41	0.46	0.50	0.51	0.49	0.51	0.54	0.63	0.66
	75/63 (23.89/17.22)		0.42	0.43	0.49	0.54	0.54	0.52	0.54	0.57	0.67	0.70
	80/67 (26.67/19.44)		0.44	0.45	0.53	0.59	0.58	0.56	0.57	0.60	0.70	0.74
	90/73 (32.22/22.78)		0.48	0.49	0.60	0.66	0.64	0.59	0.63	0.66	0.78	0.81

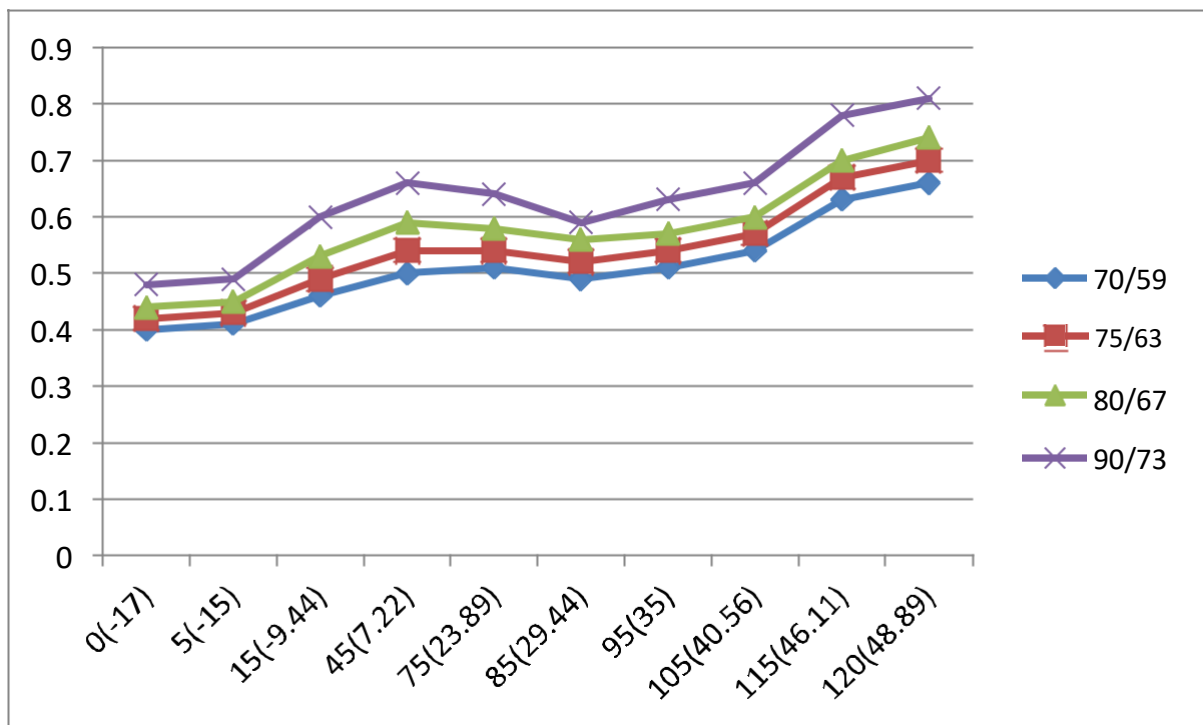

### Heating chart(R22):

°F(°C)	ODU(DB/WB)	57/53 (13.89/11.67)	47/43 (8.33/6.11)	37/33 (2.78/0.56)	27/23 (-2.78/-5)	17/13 (-8.33/ -10.56)	0/-2 (-17/-19)	-17/-18 (-27/-28)
	IDU(DB)							
BAR	55(12.78)	18.9	17.8	15.8	14.3	13.0	11.6	10.3
	65(18.33)	20.3	18.8	16.6	15.9	14.6	12.8	11.9
	75(23.89)	21.1	19.7	17.3	16.4	15.6	13.4	12.5
PSI	55(12.78)	274	258	229	207	189	168	149
	65(18.33)	294	273	241	231	212	186	172.6
	75(23.89)	306	286	251	238	226	194	181
MPa	55(12.78)	1.89	1.78	1.58	1.43	1.30	1.16	1.03
	65(18.33)	2.03	1.88	1.66	1.59	1.46	1.28	1.19
	75(23.89)	2.11	1.97	1.73	1.64	1.56	1.34	1.25

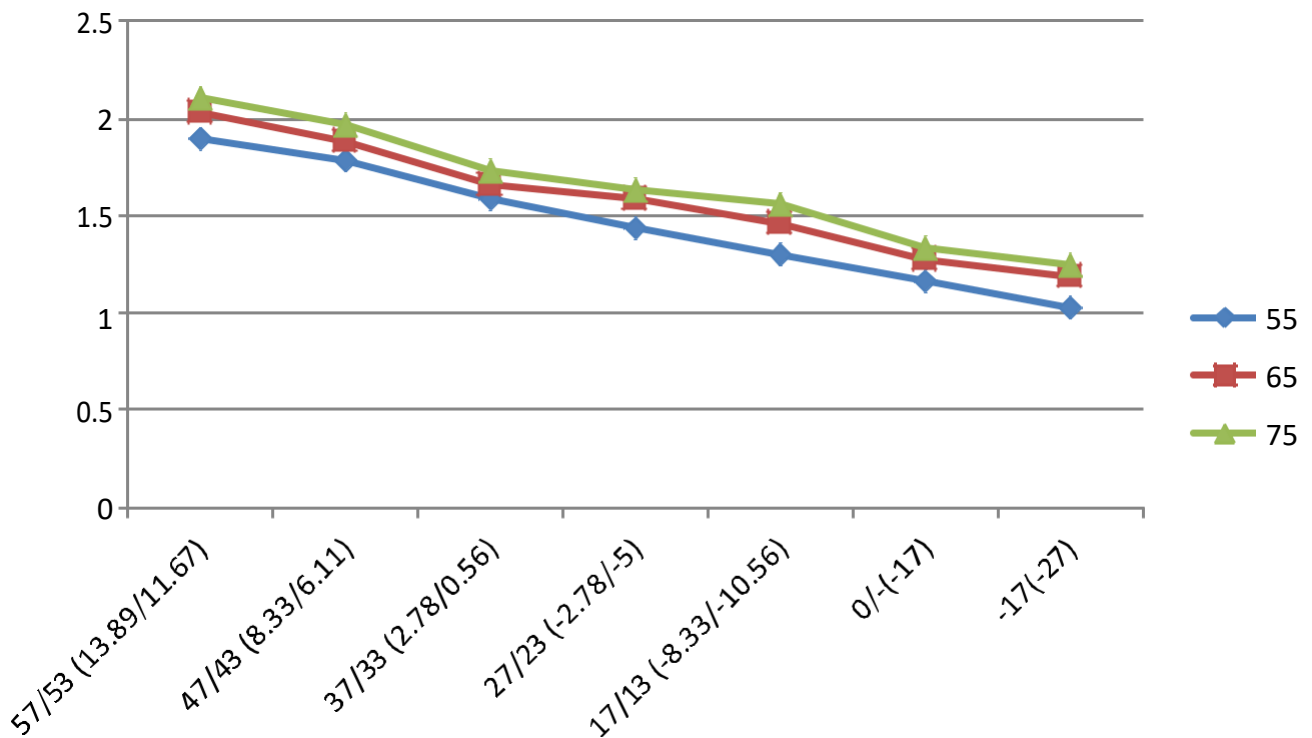

### Cooling chart(R32):

°F(°C)	ODU(DB)		0(-17)	5(-15)	15(-9.44)	45(7.22)	75(23.89)	85(29.44)	95(35)	105(40.56)	115(46.11)	120(48.89)
	IDU(DB/WB)											
BAR	70/59 (21.11/15)		6.5	6.6	7.4	8.2	8.4	8.0	8.3	8.8	10.3	10.8
	75/63 (23.89/17.22)		6.8	6.9	8.1	8.8	8.8	8.5	8.9	9.3	10.9	11.4
	80/67 (26.67/19.44)		7.2	7.3	8.7	9.7	9.5	9.1	9.3	9.8	11.4	12.1
	90/73 (32.22/22.78)		7.9	8.0	9.8	10.7	10.5	9.7	10.2	10.8	12.6	13.3
PSI	70/59 (21.11/15)		95	96	108	118	121	115	119	128	150	157
	75/63 (23.89/17.22)		99	101	117	128	126	122	129	135	158	165
	80/67 (26.67/19.44)		105	106	125	141	138	132	135	143	165	176
	90/73 (32.22/22.78)		114	115	142	155	152	141	148	157	184	193
MPa	70/59 (21.11/15)		0.65	0.66	0.74	0.82	0.84	0.80	0.83	0.88	1.03	1.08
	75/63 (23.89/17.22)		0.68	0.69	0.81	0.88	0.88	0.85	0.89	0.93	1.09	1.14
	80/67 (26.67/19.44)		0.72	0.73	0.87	0.97	0.95	0.91	0.93	0.98	1.14	1.21
	90/73 (32.22/22.78)		0.79	0.80	0.98	1.07	1.05	0.97	1.02	1.08	1.26	1.33

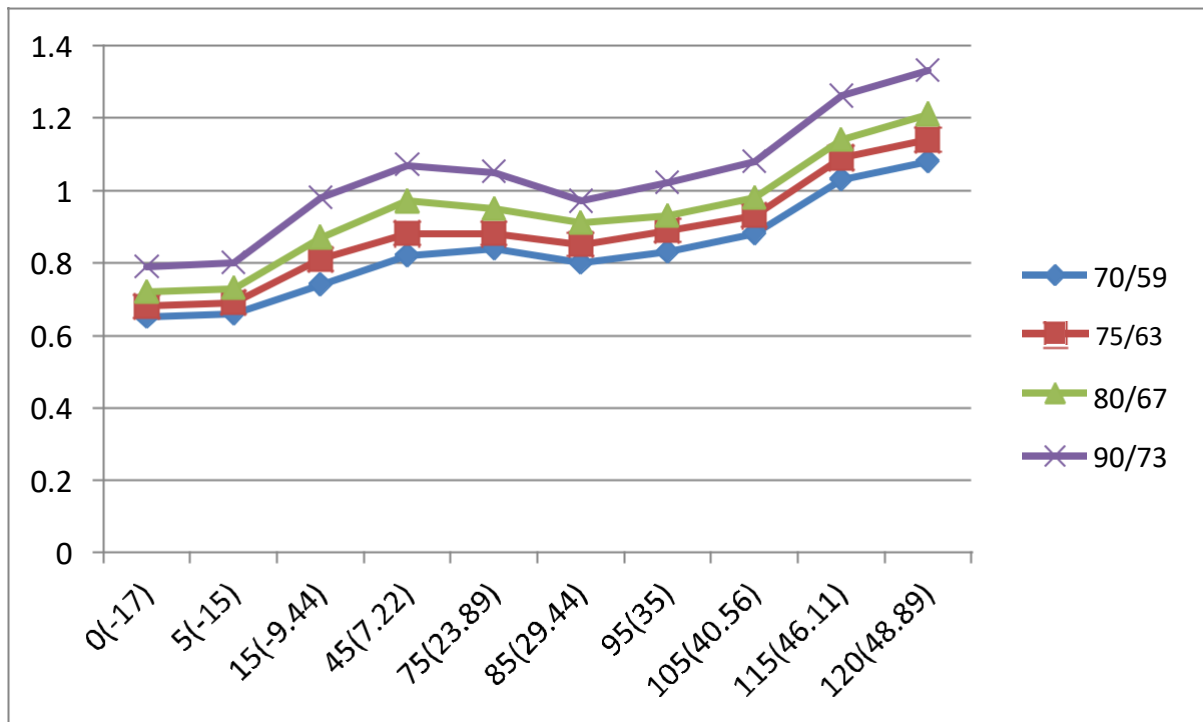

### Heating chart(R32):

°F(°C)	QDU(DB/WB)	57/53 (13.89/11.67)	47/43 (8.33/6.11)	37/33 (2.78/0.56)	27/23 (-2.78/-5)	17/13 (-8.33/- 10.56)	0/-2 (-17/-19)	-17/-18 (-27/-28)
	IDU(DB)							
BAR	55(12.78)	30.9	29.1	25.8	23.3	21.2	18.9	16.8
	65(18.33)	33.2	30.6	27.1	25.9	23.8	20.9	19.4
	75(23.89)	34.5	32.1	28.4	26.8	25.4	21.9	20.4
PSI	55(12.78)	448	421	374	337	308	273	244
	65(18.33)	480	444	394	375	346	303	282
	75(23.89)	499	466	411	389	369	318	296
MPa	55(12.78)	3.09	2.91	2.58	2.33	2.12	1.89	1.68
	65(18.33)	3.32	3.06	2.71	2.59	2.38	2.09	1.94
	75(23.89)	3.45	3.21	2.84	2.68	2.54	2.19	2.04

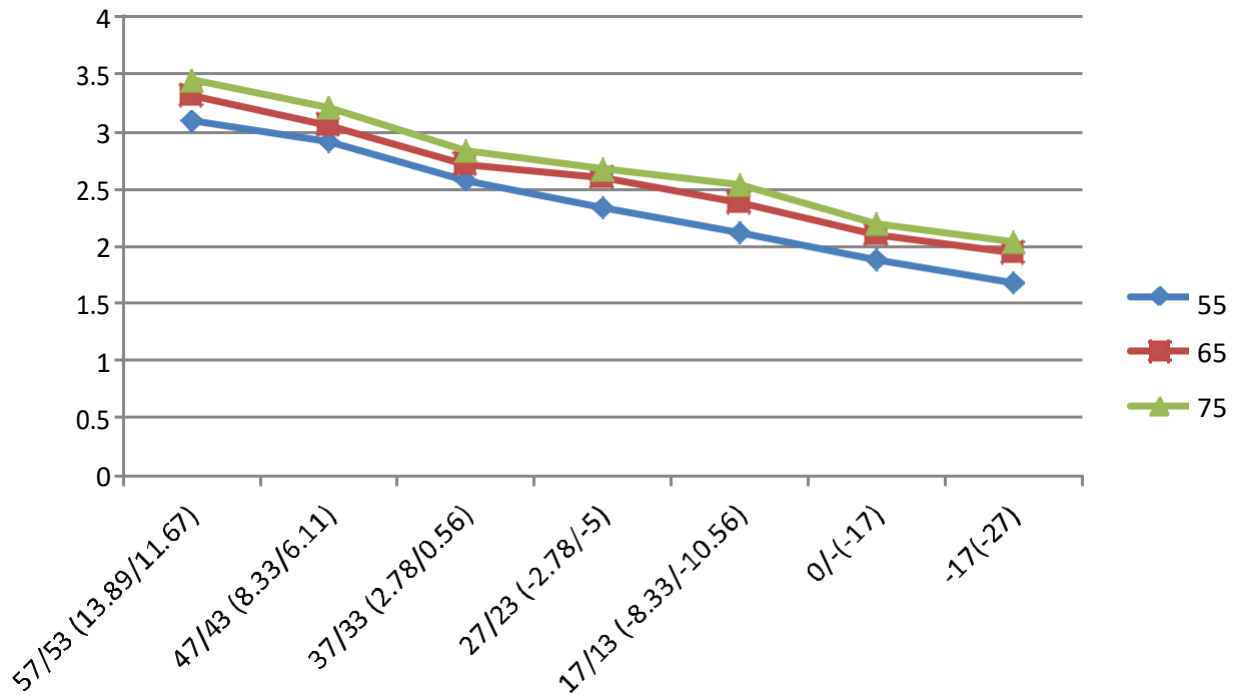

## System Pressure Table-R22

Pressure			Temperature		Pressure			Temperature	
Kpa	bar	PSI	°C	°F	Kpa	bar	PSI	°C	°F
100	1	14.5	-41.091	-41.964	1600	16	232	41.748	107.146
150	1.5	21.75	-32.077	-25.739	1650	16.5	239.25	43.029	109.452
200	2	29	-25.177	-13.319	1700	17	246.5	44.281	111.706
250	2.5	36.25	-19.508	-3.114	1750	17.5	253.75	45.506	113.911
300	3	43.5	-14.654	5.623	1800	18	261	46.706	116.071
350	3.5	50.75	-10.384	13.309	1850	18.5	268.25	47.882	118.188
400	4	58	-6.556	20.199	1900	19	275.5	49.034	120.261
450	4.5	65.25	-3.075	26.464	1950	19.5	282.75	50.164	122.295
500	5	72.5	0.124	32.223	2000	20	290	51.273	124.291
550	5.5	79.75	3.091	37.563	2050	20.5	297.25	52.361	126.250
600	6	87	5.861	42.550	2100	21	304.5	53.43	128.174
650	6.5	94.25	8.464	47.234	2150	21.5	311.75	54.48	130.064
700	7	101.5	10.92	51.656	2200	22	319	55.512	131.922
750	7.5	108.75	13.249	55.848	2250	22.5	326.25	56.527	133.749
800	8	116	15.465	59.837	2300	23	333.5	57.526	135.547
850	8.5	123.25	17.58	63.644	2350	23.5	340.75	58.508	137.314
900	9	130.5	19.604	67.287	2400	24	348	59.475	139.055
950	9.5	137.75	21.547	70.785	2450	24.5	355.25	60.427	140.769
1000	10	145	23.415	74.147	2500	25	362.5	61.364	142.455
1050	10.5	152.25	25.216	77.389	2550	25.5	369.75	62.288	144.118
1100	11	159.5	26.953	80.515	2600	26	377	63.198	145.756
1150	11.5	166.75	28.634	83.541	2650	26.5	384.25	64.095	147.371
1200	12	174	30.261	86.470	2700	27	391.5	64.98	148.964
1250	12.5	181.25	31.839	89.310	2750	27.5	398.75	65.852	150.534
1300	13	188.5	33.371	92.068	2800	28	406	66.712	152.082
1350	13.5	195.75	34.86	94.748	2850	28.5	413.25	67.561	153.610
1400	14	203	36.308	97.354	2900	29	420.5	68.399	155.118
1450	14.5	210.25	37.719	99.894	2950	29.5	427.75	69.226	156.607
1500	15	217.5	39.095	102.371	3000	30	435	70.042	158.076
1550	15.5	224.75	40.437	104.787					

## System Pressure Table-R410A

Pressure			Temperature		Pressure			Temperature	
Kpa	bar	PSI	°C	°F	Kpa	bar	PSI	°C	°F
100	1	14.5	-51.623	-60.921	2350	23.5	340.75	38.817	101.871
150	1.5	21.75	-43.327	-45.989	2400	24	348	39.68	103.424
200	2	29	-36.992	-34.586	2450	24.5	355.25	40.531	104.956
250	2.5	36.25	-31.795	-25.231	2500	25	362.5	41.368	106.462
300	3	43.5	-27.351	-17.232	2550	25.5	369.75	42.192	107.946
350	3.5	50.75	-23.448	-10.206	2600	26	377	43.004	109.407
400	4	58	-19.953	-3.915	2650	26.5	384.25	43.804	110.847
450	4.5	65.25	-16.779	1.798	2700	27	391.5	44.592	112.266
500	5	72.5	-13.863	7.047	2750	27.5	398.75	45.37	113.666
550	5.5	79.75	-11.162	11.908	2800	28	406	46.136	115.045
600	6	87	-8.643	16.444	2850	28.5	413.25	46.892	116.406
650	6.5	94.25	-6.277	20.701	2900	29	420.5	47.638	117.748
700	7	101.5	-4.046	24.716	2950	29.5	427.75	48.374	119.073
750	7.5	108.75	-1.933	28.521	3000	30	435	49.101	120.382
800	8	116	0.076	32.137	3050	30.5	442.25	49.818	121.672
850	8.5	123.25	1.993	35.587	3100	31	449.5	50.525	122.945
900	9	130.5	3.826	38.888	3150	31.5	456.75	51.224	124.203
950	9.5	137.75	5.584	42.052	3200	32	464	51.914	125.445
1000	10	145	7.274	45.093	3250	32.5	471.25	52.596	126.673
1050	10.5	152.25	8.901	48.022	3300	33	478.5	53.27	127.886
1100	11	159.5	10.471	50.848	3350	33.5	485.75	53.935	129.083
1150	11.5	166.75	11.988	53.578	3400	34	493	54.593	130.267
1200	12	174	13.457	56.223	3450	34.5	500.25	55.243	131.437
1250	12.5	181.25	14.879	58.782	3500	35	507.5	55.885	132.593
1300	13	188.5	16.26	61.268	3550	35.5	514.75	56.52	133.736
1350	13.5	195.75	17.602	63.684	3600	36	522	57.148	134.866
1400	14	203	18.906	66.031	3650	36.5	529.25	57.769	135.984
1450	14.5	210.25	20.176	68.317	3700	37	536.5	58.383	137.089
1500	15	217.5	21.414	70.545	3750	37.5	543.75	58.99	138.182
1550	15.5	224.75	22.621	72.718	3800	38	551	59.591	139.264
1600	16	232	23.799	74.838	3850	38.5	558.25	60.185	140.333
1650	16.5	239.25	24.949	76.908	3900	39	565.5	60.773	141.391
1700	17	246.5	26.074	78.933	3950	39.5	572.75	61.355	142.439
1750	17.5	253.75	27.174	80.913	4000	40	580	61.93	143.474
1800	18	261	28.251	82.852	4050	40.5	587.25	62.499	144.498
1850	18.5	268.25	29.305	84.749	4100	41	594.5	63.063	145.513
1900	19	275.5	30.338	86.608	4150	41.5	601.75	63.62	146.516
1950	19.5	282.75	31.351	88.432	4200	42	609	64.172	147.510
2000	20	290	32.344	90.219	4250	42.5	616.25	64.719	148.494
2050	20.5	297.25	33.319	91.974	4300	43	623.5	65.259	149.466
2100	21	304.5	34.276	93.697	4350	43.5	630.75	65.795	150.431
2150	21.5	311.75	35.215	95.387	4400	44	638	66.324	151.383
2200	22	319	36.139	97.050	4450	44.5	645.25	66.849	152.328
2250	22.5	326.25	37.047	98.685	4500	45	652.5	67.368	153.262
2300	23	333.5	37.939	100.290					

## System Pressure Table-R32

Pressure			Temperature		Pressure			Temperature	
Kpa	bar	PSI	°C	°F	Kpa	bar	PSI	°C	°F
100	1	14.5	-51.909	-61.436	1850	18.5	268.25	28.425	83.165
150	1.5	21.75	-43.635	-46.543	1900	19	275.5	29.447	85.005
200	2	29	-37.323	-35.181	1950	19.5	282.75	30.448	86.806
250	2.5	36.25	-32.15	-25.87	2000	20	290	31.431	88.576
300	3	43.5	-27.731	-17.916	2050	20.5	297.25	32.395	90.311
350	3.5	50.75	-23.85	-10.93	2100	21	304.5	33.341	92.014
400	4	58	-20.378	-4.680	2150	21.5	311.75	34.271	93.688
450	4.5	65.25	-17.225	0.995	2200	22	319	35.184	95.331
500	5	72.5	-14.331	6.204	2250	22.5	326.25	36.082	96.948
550	5.5	79.75	-11.65	11.03	2300	23	333.5	36.965	98.537
600	6	87	-9.150	15.529	2350	23.5	340.75	37.834	100.101
650	6.5	94.25	-6.805	19.752	2400	24	348	38.688	101.638
700	7	101.5	-4.593	23.734	2450	24.5	355.25	39.529	103.152
750	7.5	108.75	-2.498	27.505	2500	25	362.5	40.358	104.644
800	8	116	-0.506	31.089	2550	25.5	369.75	41.173	106.111
850	8.5	123.25	1.393	34.507	2600	26	377	41.977	107.559
900	9	130.5	3.209	37.777	2650	26.5	384.25	42.769	108.984
950	9.5	137.75	4.951	40.911	2700	27	391.5	43.55	110.39
1000	10	145	6.624	43.923	2750	27.5	398.75	44.32	111.776
1050	10.5	152.25	8.235	46.823	2800	28	406	45.079	113.142
1100	11	159.5	9.790	49.621	2850	28.5	413.25	45.828	114.490
1150	11.5	166.75	11.291	52.324	2900	29	420.5	46.567	115.821
1200	12	174	12.745	54.941	2950	29.5	427.75	47.296	117.133
1250	12.5	181.25	14.153	57.475	3000	30	435	48.015	118.427
1300	13	188.5	15.52	59.936	3050	30.5	442.25	48.726	119.707
1350	13.5	195.75	16.847	62.325	3100	31	449.5	49.428	120.970
1400	14	203	18.138	64.648	3150	31.5	456.75	50.121	122.218
1450	14.5	210.25	19.395	66.911	3200	32	464	50.806	123.451
1500	15	217.5	20.619	69.114	3250	32.5	471.25	51.482	124.668
1550	15.5	224.75	21.813	71.263	3300	33	478.5	52.15	125.87
1600	16	232	22.978	73.360	3350	33.5	485.75	52.811	127.060
1650	16.5	239.25	24.116	75.409	3400	34	493	53.464	128.235
1700	17	246.5	25.229	77.412	3450	34.5	500.25	54.11	129.398
1750	17.5	253.75	26.317	79.371	3500	35	507.5	54.748	130.546
1800	18	261	27.382	81.288					